



***OWNER'S/OPERATOR'S  
MANUAL***

**Europe 4, 5 & T3 EFI**

**WARNING:**

Read this Manual,  
and any Supplements  
Carefully  
Before Operating  
Vehicle.

- Assembly
- Operation
- Maintenance

**THIS VEHICLE IS NOT  
DESIGNED FOR  
USE ON RENTAL  
TRACKS OR RACING**

**ATV 570 ProMax  
4X4**

**BEFORE OPERATING THIS VEHICLE, THE OWNER AND EACH OPERATOR  
MUST HAVE READ AND HAVE AN UNDERSTANDING OF ALL THE  
INSTRUCTIONS FOR PROPER ASSEMBLY AND SAFE OPERATION, AS  
WELL AS THE INSTRUCTIONS CONCERNING THE ENGINE AND ALL  
OTHER PORTIONS OF THE VEHICLE.**

This manual for the English version

# CONTENTS

1. INTRODUCTION .....	1.3
2. UNDERSTANDING WARNING .....	2.6
3. SAFETY WARNING .....	3.8
4. DAILY PRE-RIDE INSPECTION .....	4.15
5. OPERATION WARNING .....	5.16
6. V.I.N., ENGINE SERIAL NUMBER AND KEY .....	6.32
7. CONTROL AND FUNCTIONS .....	7.33
8. STARTING THE ENGINE .....	8.48
9. VEHICLE BREAK-IN PERIOD .....	9.51
10. RIDING GEAR .....	10.52
11. RIDING .....	11.53
12. CVT SYSTEM .....	12.65
13. CARRYING LOADS .....	13.67
14. BATTERY .....	14.70
15. EXHAUST SYSTEM .....	15.73
16. MAINTENANCE .....	16.75
17. TROUBLE SHOOTING .....	17.99
18. TOOLS .....	18.106
19. SPECIFICATION .....	19.107

# 1. Introduction

---

Congratulations on the purchase of your ALL Terrain Vehicle (ATV). We take pride in offering you this product engineered and manufactured to the highest performance and quality standards. We are sure that you will enjoy superior levels of performance, reliability, riding comfort, and safety.

This manual is provided to help the owner and operators of this ATV become familiar with the operating characteristic, and the many features offered on the ATV. The manual also covers information on the care and maintenance of your ATV.

Please read this manual carefully. The information contained in this Owner's Manual, the Warning Labels supplied with this product will help you to understand the safe use and maintenance of your ATV. Make sure that you understand and follow all Warnings and Instructions in this material.

If you did not receive any of the material listed above, please call your dealer and request to have them sent to you.

## Important Safety Notice

Never make any modifications to the engine, drive system, mechanical or electrical systems of your ATV. Never install aftermarket parts or accessories intended to increase the speed or power of your ATV.

Failure to follow these warnings increases the possibility of accidents leading to **DEATH** or **SERIOUS INJURY!**

Additionally, failure to follow these requirements will void the Warranty on your ATV.

### NOTE

The addition and use of certain accessories including, (but not limited to) mowers, blades, sprayers, winches and windshields will change the handling characteristics and the performance of your ATV.

## Practice Responsible ATV Riding

Make sure that you understand and follow all local, state/province, and federal/national riding laws and requirements.

Remember.....Respect your vehicle, respect the environment and respect the property of others. You are responsible for your safety and the safety of others around you when you ride!

**AN ATV CAN BE HAZARDOUS TO OPERATE.** An ATV handles differently from other vehicles including motorcycles and cars. A collision

# 1. Introduction

rollover can occur quickly, even during routine maneuvers such as turning and driving on hills or over obstacles, if you fail to take proper precautions.



**SERIOUS INJURY OR DEATH** can result if you do not follow these instructions.

- Read this manual and all labels carefully and follow the operating procedures described.
- Never operate an ATV without proper instruction. Take a training course. Beginners should receive training from a certified instructor. Contact an authorized ATV dealer to find out about the training courses nearest you.
- Never allow anyone who is not an adult to operate this ATV.
- Never permit a guest to operate this ATV unless the guest has read this manual and all product labels, and has completed a certified training course.
- Never operate an ATV without wearing an approved helmet that fits properly. You should also wear eye protection (goggles or face shield), gloves, boots, long-sleeved shirt or jacket, and long pants.
- Never consume alcohol or drugs before or while operating this ATV.
- Never operate at excessive speeds. Always travel at a speed which is proper for the terrain, visibility and operating conditions, and your experience.
- Never attempt wheelies, jumps or other stunts.
- Always inspect your ATV each time you use it to make sure it is in safe operating condition. Always follow the inspection and maintenance procedures and schedules described in this manual.
- Always keep both hands on the handlebars and both feet on the footrests of the ATV during operation.
- Always go slowly and be extra careful when operating on unfamiliar terrain. Always be alert to changing terrain conditions when operating the ATV.
- Never operate on excessively rough, slippery or loose terrain.
- Always follow proper procedures for turning as described in this manual. Practice turning at low speeds before attempting to turn at faster speeds. Do not turn at excessive speed.
- Always have the ATV checked by an authorized dealer if it has been involved in an accident.
- Never operate ATV on hills too steep for the ATV or for your abilities. Practice on smaller hills before attempting larger hills.
- Always follow proper procedures for climbing hills as described in this manual. Check the terrain carefully before you start up any hill. Never climb hills with excessively slippery or loose surfaces. Shift your weight forward. Never open throttle suddenly or make sudden gear changes. Never go over the top of any hill at high speed.
- Always follow proper procedures for going down hills and for braking on hills as described in this manual. Check the terrain carefully before you

# 1. Introduction

---

start down any hill. Shift your weight backward. Never go down a hill at high speed. Avoid going down a hill at an angle which would cause the vehicle to lean sharply to one side. Go straight down the hill where possible.

- Always follow proper procedures for crossing the side of a hill as described in this manual. Avoid hills with excessively slippery or loose surfaces. Shift your weight to the uphill side of the ATV. Never attempt to turn the ATV around on any hill until you have mastered the turning technique described in this manual on level ground. Avoid crossing the side of a steep hill if possible.
- Always use proper procedures if you stall or roll backwards when climbing a hill. To avoid stalling, maintain a steady speed when climbing a hill. If you stall or roll backwards, follow the special procedure for braking described in this manual. Dismount on the uphill side or to either side if pointed straight uphill. Turn the ATV around and remount, following the procedure described in this manual.
- Always check for obstacles before operating in a new area. Never attempt to operate over large obstacles, such as large rocks or fallen trees. Always follow proper procedures when operating over obstacles as described in this manual.
- Always be careful of skidding or sliding. On slippery surfaces, such as ice, go slowly and be very cautious in order to reduce the chance of skidding or sliding out of control.
- Avoid operating the ATV through deep or fast flowing water. Avoid water which exceeds the recommended maximum depth. Go slowly, balance your weight carefully avoiding sudden movements, maintain a slow and steady forward motion, do not make sudden turns or stops, and do not make sudden throttle changes.
- Wet brakes may have reduced stopping ability. Test your brakes after leaving water. If necessary apply them lightly several times to let friction dry out the pads.
- Always be sure there are no obstacles or people behind you when you operate in reverse. When it is safe to proceed in reverse, go slowly. Avoid turning at sharp angles in reverse.
- Always use the size and type tires specified in this manual. Always maintain proper tire pressure as described in this manual.
- Never modify an ATV through improper installation or use of accessories
- Never exceed the stated load capacity for an ATV. Cargo should be properly distributed and securely attached. Reduce speed and follow instructions in this manual for carrying cargo or pulling a trailer. Allow greater distance for braking.

## 2. UNDERSTANDING WARNINGS

---

### ATTENTION:

This is an ADULT VEHICLE ONLY: not a toy. READ AND UNDERSTAND WARNINGS AND OWNER'S MANUAL BEFORE OPERATION.



**KNOW YOUR VEHICLE BEFORE YOU BEGING RIDING!**

Read this manual thoroughly referring to the various areas which are being discussed on your machine. Operating this vehicle carries with it responsibilities for your personal safety, the safety of others, and the protection of our environment.

**NOTE:** Illustrations used in this manual are for general representation only.

Your model may differ.

## 2. UNDERSTANDING WARNINGS

---

### SAFETY ALERT

**WARNINGS** identify special instructions or procedures which, if not correctly followed, could result in personal injury, or loss of life. Read all **WARNINGS** in this manual carefully. Follow their instructions to remain safe.

The following precautionary signal words are used throughout this manual to convey the following messages:



This is the safety alert symbol. When you see this symbol on your machine or in this manual, be alert to the potential for personal injury. Your safety is involved!



**WARNING**

**Indicates a potential hazard which could result in severe injury or death.**

---



**CAUTION**

**Indicates a potential hazard which may result in minor personal injury or damage to the ATV.**

---

**CAUTION**

**Indicates a situation that can result in damage to the machine.**

---

**NOTE** The word “NOTE” in this manual will alert you to key information or instructions.

### 3. SFETY WARNING

**Attention:** There is a risk of fire from driving the vehicle on the ground where grass has dried up or parking the vehicle on such surface while the engine is hot.

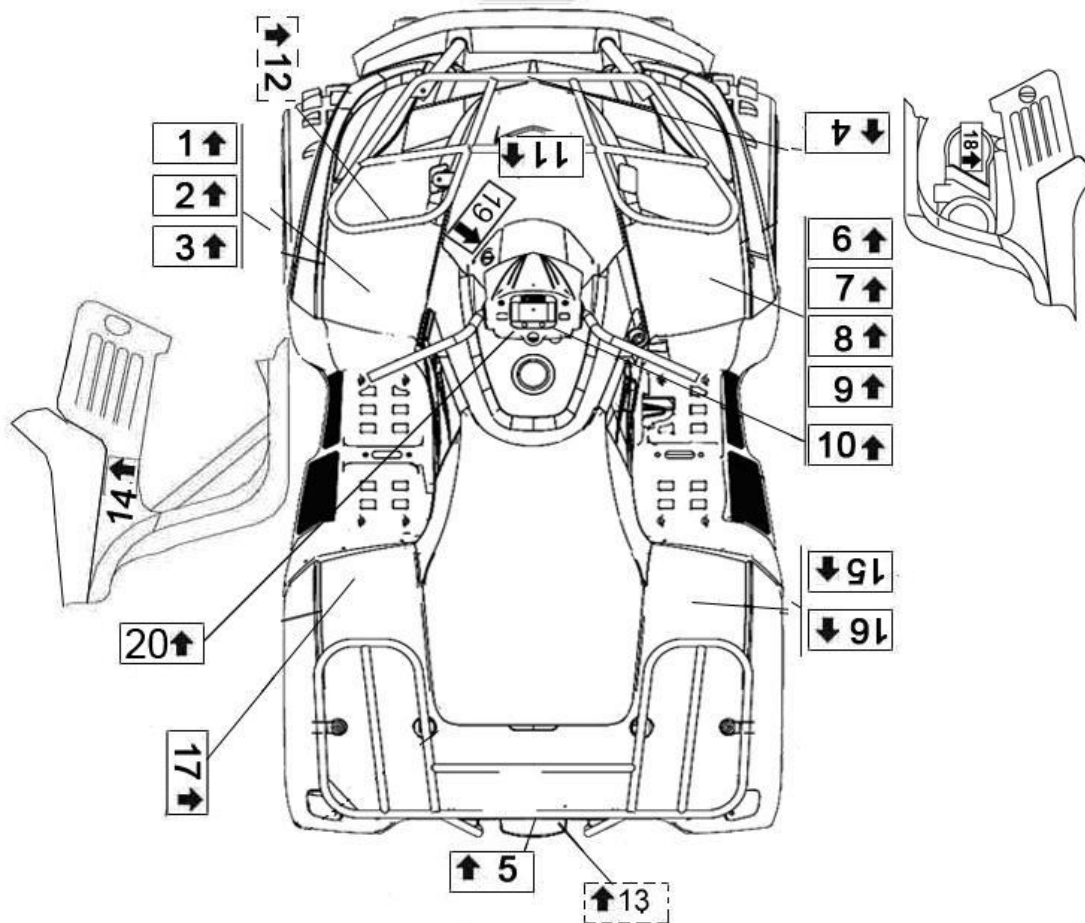

**NOTE:**

Warning decals have been placed on the vehicle for your protection. Read and follow the instructions on each decal carefully. In the event any decal becomes illegible or comes off, contact your dealer for a replacement.

**Attention:** There is a risk of fire from driving the vehicle on the ground where grass has driven up or parking the vehicle on such surface while the engine is hot.

1.

! NOTE

Use 4WD only when necessary, this will result in less fuel consumption and longer life for the machine.

T02021



### 3. SFETY WARNING

2.

 **WARNING**

Never activate the override button while throttle is open as loss of control may result, causing severe personal injury or death.

T02018

3.

 **WARNING**

**Improper ATV use can result in SEVERE INJURY or DEATH**



**ALWAYS USE AN APPROVED HELMET AND PROTECTIVE GEAR**



**NEVER CARRY MORE THAN ONE PASSENGER**



**NEVER USE WITH DRUGS OR ALCOHOL**

**NEVER** carry a passenger too small to firmly plant feet on footrests and securely grasp hand holds.

**THE PASSENGER MUST ALWAYS:**

- use an approved helmet and protective gear
- securely grasp hand holds and plant feet firmly on footrests while seated in the passenger seat
- tell operator to slow down or stop if uncomfortable -get off and walk if conditions require

**NEVER** operate:

- without proper training or instruction
- at speeds too fast for your skills or the conditions

**ALWAYS:**

- use proper riding techniques to avoid vehicle overturns on hills and rough terrain and in turns

**LOCATE AND READ OWNER'S MANUAL.  
FOLLOW ALL INSTRUCTIONS AND WARNINGS.**

T02148

4.

### 3. SFETY WARNING

 **WARNING**

● DO NOT TOW FROM BACK OR BUMPER. Vehicle damage or tip over may result cause severe Injury or death. Tow only from tow hooks or hitch. ● Max.combined Front Rack and container Load 40lbs/18kg. T02038

5.

 **WARNING**

● DO NOT TOW FROM BACK OR BUMPER. Vehicle damage or tip over may result cause severe Injury or death. Tow only from tow hooks or hitch. ● Max.Rear Rack Load 80lbs/36kg. T02039

6.

 **CAUTION**

When switching to the 2WD position from 4WD, the button will stay in the 2WD position but the 4WD mechanism maybe still be engaged.  
The 4WD will finally disengage when riding on a hard surface or riding in reverse.  
The 2WD indicator on the speedometer will come on when 4WD is disengaged. T02020

7.

**CAUTION**

To avoid transmission breakages use the shift lever only while the vehicle is standing still and the engine is running at idle speed. T02017

8.

**CAUTION**

**TO KEEP THE CLUTCH & TRANSMISSION IN GOOD CONDITIONS.**  
**Use:**  
**Low Range:**

- Basic operation at speeds less than 11km/h
- Heavy pulling
- Riding through rough terrain (swamps,mountains,etc.)at low ground speeds

**High Range:**

- Basic operation at speeds greater than 11km/h
- High ground speeds. T02016

9.

### 3. SFETY WARNING

---



10.

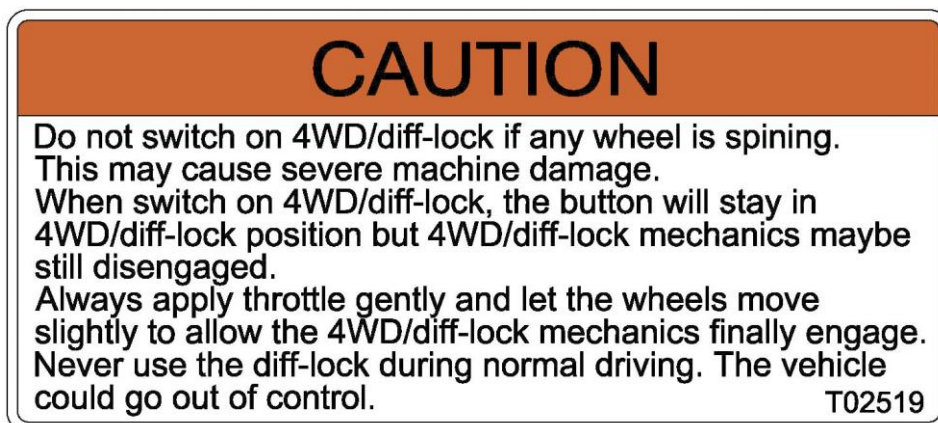

11.

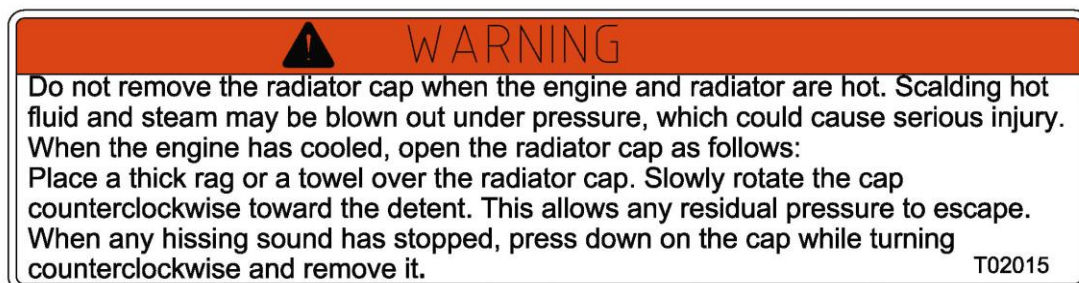

12.

### 3. SFETY WARNING

---

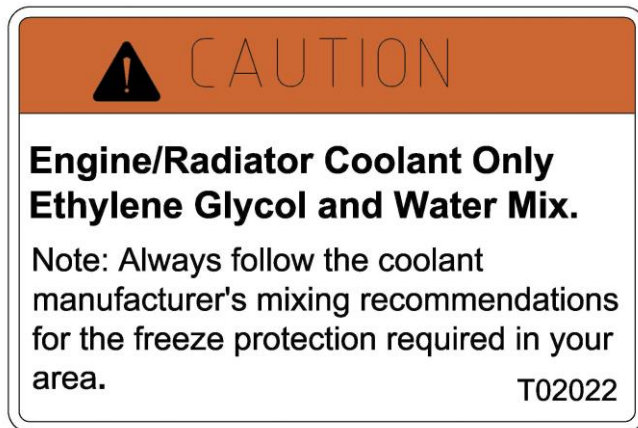

13.

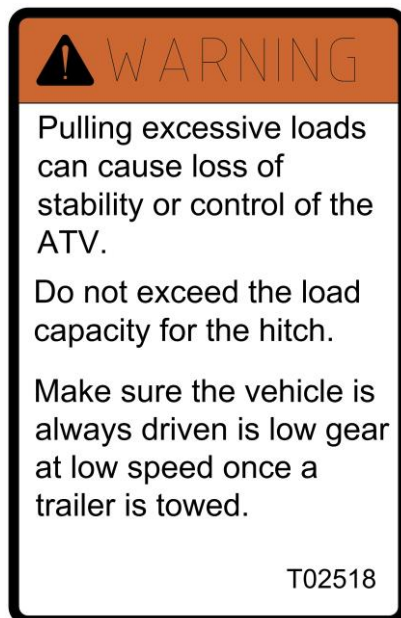

14.

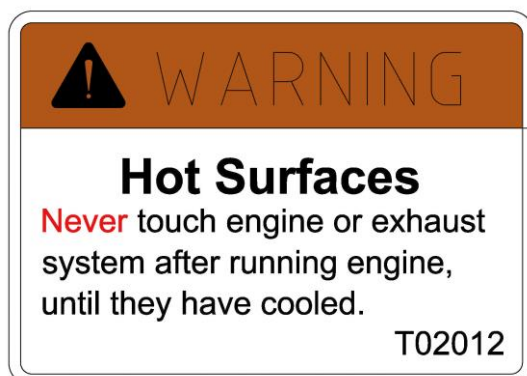

15.

### 3. SFETY WARNING

---

WARNING

**Never** Operate this vehicle on HILLS steeper than 15% gradient.  
To prevent flip over on hilly terrain, use the throttle and brake gradually.

Operation of the ATV in reverse, even at low speeds can be dangerous.  
Steering and control of the ATV can become difficult.

To prevent flip over, avoid sudden braking and sharp turns.

T02013

16.

WARNING

Attempting to shift the operating range of the transmission, or to shift into or out four wheel drive while the ATV is in motion or the engine speed higher than idle can cause loss of control of the ATV or severe damage to the transmission and drive system.

Never attempt to shift the operating range of the transmission or to shift into or out four wheel drive while the ATV is in motion or the engine speed higher than idle.

T02019

17.

WARNING

Improper tire pressure or overloading can cause loss of control.  
Loss of control can result in severe injury or death.

- Recommended cold tire pressure:  
    Front : 35 kPa ( 5psi )  
    Rear : 35 kPa ( 5psi )
- Maximum weight capacity : 350 lbs.(150kg)

T02697

18.

### 3. SFETY WARNING

---



19

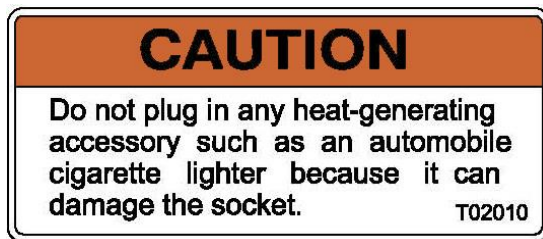

20

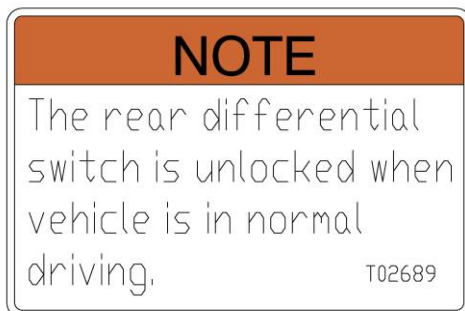

## 4. DAILY PRE-RIDE INSPECTION

---



### WARNING

You must inspect your ATV each time before riding to ensure it is in proper working order. If proper inspection is not done, severe injury or death could result.

---

Use the following checklist to verify your machine is in proper working order each time you ride.

#### **Item/Inspection procedure**

1. Tire-check condition and pressures.
2. Fuel tank-fill the fuel tank to its proper level.
3. All brakes-check operation, adjustment and fluid level (includes auxiliary brake).
4. Throttle-check for free operation and closing.
5. Headlight / Taillight / Brakelight-check operation of all indicator lights and switches.
6. Engine stop switch-check for proper function.
7. Wheels-check for tightness of wheel nuts and axle nuts; check that axle nuts are secured by cotter pins.
8. Air cleaner element-check for dirt; clean or replace.
9. Steering-check for free operation noting any unusual looseness in any area.
10. Loose parts-visually inspect vehicle for any damaged components or loose nuts/bolts or fasteners.
11. Operators helmets, goggles and clothing.
12. Engine coolant check for proper level at the recovery bottle.

## 5. OPERATION WARNINGS

---

### Get on and leave ATV

#### Get on

Get on the ATV through left or right by steps.

#### Leave

Check that the surroundings are in safe condition and then slowly park the ATV.

Stop the engine. (Key off)

Push the parking lever to the ON position to lock the rear wheels.

Leave the ATV through left or right steps.



### WARNING

#### POTENTIAL HAZARD

Operating this ATV without proper instruction.

#### WHAT CAN HAPPEN

The risk of an accident is greatly increased if operator does not know how to operate the ATV properly in different situations and on different types of terrain.

#### HOW TO AVOID THE HAZARD

Beginning and inexperienced operators should complete the certified training course. They should then regularly techniques described in the Owner's Manual.

For more information about the training course, contact an authorized ATV dealer.



### WARNING

#### POTENTIAL HAZARD

Operating this ATV without wearing an approved helmet, eye protection and protective clothing.

#### WHAT CAN HAPPEN

Operating without an approved helmet increases your chances of a severe head injury or death in the event of an accident.

Operating without eye protection can result in an accident and increases your chances of a severe injury in the event of an accident.

#### HOW TO AVOID THE HAZARD

Always wear an approved helmet which fits properly.

You should also wear: eye protection (goggles or face shield); gloves; boots; long-sleeved shirt or jacket; and long pants.



## 5. OPERATION WARNINGS

---



### WARNING

#### **POTENTIAL HAZARD**

Operating this ATV after consuming alcohol or drugs.

#### **WHAT CAN HAPPEN**

Could seriously affect your judgment.

Could cause you to react more slowly.

Could affect your balance and perception.

Could result in an accident.

#### **HOW TO AVOID THE HAZARD**

Never consume alcohol or drugs before or while driving this ATV.

---



### WARNING

#### **POTENTIAL HAZARD**

Operating this ATV at excessive speeds.

#### **WHAT CAN HAPPEN**

Increases your chances of losing control of the ATV, which can result in an accident.

#### **HOW TO AVOID THE HAZARD**

Always travel at a speed which is proper for the terrain, visibility and operating conditions; and your experience.

---

## 5. OPERATION WARNINGS

---



### WARNING

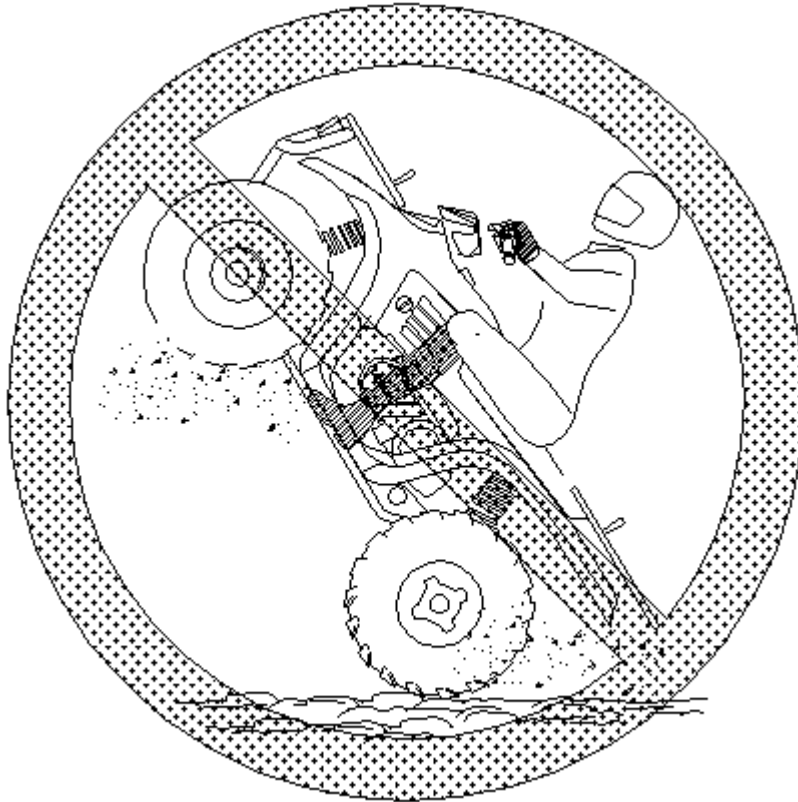

#### **POTENTIAL HAZARD**

Attempting wheelies, jumps and other stunts.

#### **WHAT CAN HAPPEN**

Increases the chance of an accident, including an overturn.

#### **HOW TO AVOID THE HAZARD**

Never attempt stunts, such as wheelies or jumps.

---



### WARNING

## 5. OPERATION WARNINGS

---

### **POTENTIAL HAZARD**

Failure to inspect the ATV before operating.  
Failure to properly maintain the ATV.

### **WHAT CAN HAPPEN**

Increases the possibility of an accident or equipment damage.

### **HOW TO AVOID THE HAZARD**

Always inspect your ATV each time you use it to make sure the ATV is in safe operating condition.

Always follow the inspection and maintenance procedures and schedules described in the Owner's Manual.



### **WARNING**

### **POTENTIAL HAZARD**

Removing hands from handlebars or feet from footrests during operation.

### **WHAT CAN HAPPEN**

Removing even one hand or foot can reduce your ability to control the ATV or could cause you to lose your balance and fall off the ATV. If you remove a foot from the footrest, your foot or leg may come into contact with the rear wheels. Which could injure you or cause an accident.

### **HOW TO AVOID THE HAZARD**

Always keep both hands on the handlebars and both feet on the footrests of your ATV during operation.



### **WARNING**

## 5. OPERATION WARNINGS

---

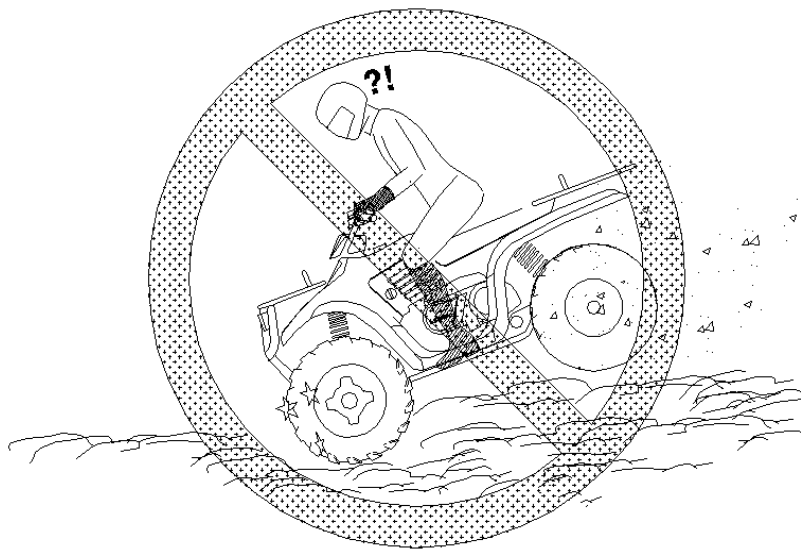

### **POTENTIAL HAZARD**

Failure to use extra care when operating this ATV on unfamiliar terrain.

### **WHAT CAN HAPPEN**

You can come upon hidden rocks, bumps, or holes, without enough time to react.

Could result in the ATV overturning or going out of control.

### **HOW TO AVOID THE HAZARD**

Go slowly and be extra careful when operating on unfamiliar terrain.

Always be alert to changing terrain conditions when operating the ATV.

---



**WARNING**

### **POTENTIAL HAZARD**

## 5. OPERATION WARNINGS

---

Failure to use extra care when operating on excessively rough, slippery or loose terrain.

### **WHAT CAN HAPPEN**

Could cause loss of traction or vehicle control, which could result in an accident, including an overturn.

### **HOW TO AVOID THE HAZARD**

Do not operate on excessively rough, slippery or loose terrain until you have learned and practiced the skills necessary to control the ATV on such terrain. Always be especially cautious on these kinds of terrain.

---



## **WARNING**

### **POTENTIAL HAZARD**

Climbing hills improperly.

### **WHAT CAN HAPPEN**

Could cause loss of control or cause ATV to overturn.

### **HOW TO AVOID THE HAZARD**

Always follow proper procedures for climbing hills as described in the Owner's Manual.

Always check the terrain carefully before you start up any hill.

Never climb hills with excessively slippery or loose surfaces.

Shift your weight forward.

Never open the throttle suddenly. The ATV could flip over backwards.

Never go over the top of any hill at high speed. An obstacle, a sharp drop, or another vehicle or person could be on the other side of the hill.

---



## **WARNING**

### **POTENTIAL HAZARD**

## 5. OPERATION WARNINGS

---

Turning improperly.

### **WHAT CAN HAPPEN**

ATV could go out of control, causing a collision or overturn.

### **HOW TO AVOID THE HAZARD**

Always follow proper procedures for turning as described in the Owner's Manual.

Practice turning at low speeds before attempting to turn at faster speeds.

Do not turn at excessive speed.

---



## **WARNING**

### **POTENTIAL HAZARD**

Operating on excessively steep hills.

### **WHAT CAN HAPPEN**

The vehicle can overturn more easily on extremely steep hills than on level surfaces or small hills.

### **HOW TO AVOID THE HAZARD**

Never operate the ATV on hills too steep for the ATV or for your abilities.

Practice on smaller hills before attempting large hills.

Never operate ATV on hills steeper than 15%.

---



## **WARNING**

### **POTENTIAL HAZARD**

Going down a hill improperly.

### **WHAT CAN HAPPEN**

Could cause loss of control or cause ATV to overturn.

### **HOW TO AVOID THE HAZARD**

## 5. OPERATION WARNINGS

---

Always follow proper procedures for going down hills as described in the Owner's Manual. NOTE: A special technique is required when braking as you go downhill.

Always check the terrain carefully before you start down any hill.

Shift your weight backward.

Never go down a hill at high speed.

Avoid going down a hill at an angle which would cause the vehicle to lean sharply to one side. Go straight down the hill where possible.



### **WARNING**

#### **POTENTIAL HAZARD**

Improperly crossing hills or turning on hills.

#### **WHAT CAN HAPPEN**

Could cause loss of control or cause ATV to overturn.

#### **HOW TO AVOID THE HAZARD**

Never attempt to turn the ATV around on any hill until you have mastered the turning technique as described in the Owner's Manual on level ground. Be very careful then turning on any hill.

Avoid crossing the side of a steep hill if possible.

#### **When crossing the side of a hill:**

Always follow proper procedures as described in the Owner's Manual.

Avoid hills with excessively slippery or loose surfaces.

Shift your weight to the uphill side of the ATV.

---



### **WARNING**

## 5. OPERATION WARNINGS

---

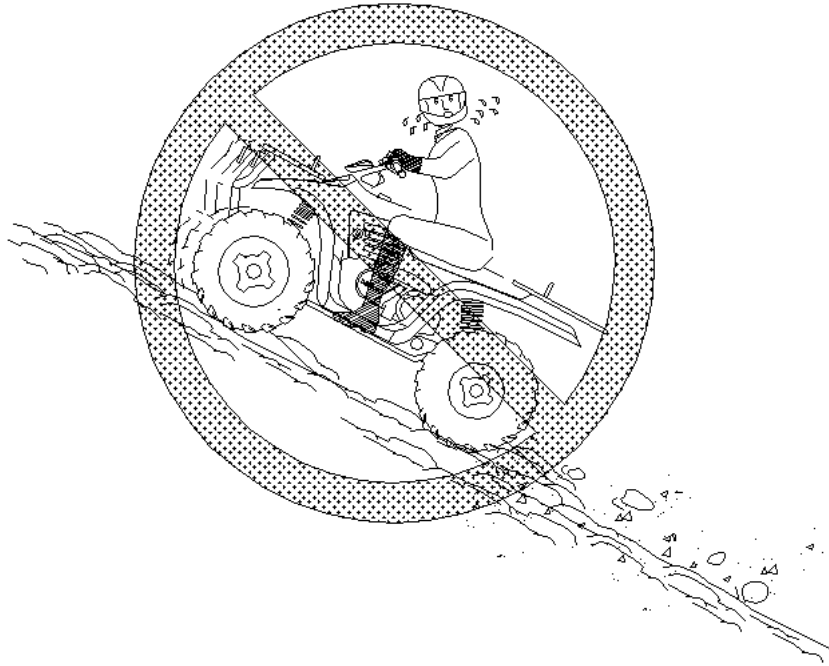

### **POTENTIAL HAZARD**

Stalling, rolling backwards or improperly dismounting while climbing a hill.

### **WHAT CAN HAPPEN**

Could result in ATV overturning.

### **HOW TO AVOID THE HAZARD**

Maintain steady speed when climbing a hill.

If you lose all forward speed:

Keep weight uphill.

Apply the brakes.

Lock parking brake after you are stopped.

If you begin rolling backwards:

Keep weight uphill; never apply engine power.

Never apply the rear brake while rolling backwards.

Apply the single-lever brake gradually.

When fully stopped, apply rear brake as well, and then lock parking brake.

Dismount on uphill side, or to either side if pointed straight uphill.

Turn the ATV around and remount following the procedure described in the Owner's Manual.

---



**WARNING**



## 5. OPERATION WARNINGS

---

### POTENTIAL HAZARD

Improperly operating over obstacles.

### WHAT CAN HAPPEN

Could cause loss of control or a collision. Could cause the ATV to overturn.

### HOW TO AVOID THE HAZARD

Before operating in a new area, check for obstacles.

Use extreme caution when riding over large obstacles, such as large rocks or fallen trees.

If you cannot avoid obstacles, always follow proper procedures as described in the Owner's Manual.

---



## WARNING

### POTENTIAL HAZARD

Skidding or sliding,

### WHAT CAN HAPPEN

You may lose control of the ATV.

You may also regain traction unexpectedly, which may cause the ATV to overturn.

### HOW TO AVOID THE HAZARD

On slippery surfaces, such as ice, go slowly and be very cautious in order to reduce the chance of skidding or sliding out of control.

---



## WARNING

## 5. OPERATION WARNINGS

---

### POTENTIAL HAZARD

Operating this ATV through deep or fast flowing water.

### WHAT CAN HAPPEN

Tires may float, causing loss of traction and loss of control, which could lead to an accident.

### HOW TO AVOID THE HAZARD

Never operating the ATV through water which exceeds the recommended maximum depth in this manual.

Avoid operating the ATV through deep or fast flowing water. If you cannot avoid water, go slowly, balance your weight carefully avoiding sudden movement, maintain a slow and steady forward motion, do not make sudden turns or stops, and do not make sudden throttle changes.

Remember that wet brakes may have reduced stopping ability.

Test your brakes after leaving water. If necessary, apply them several times to let friction dry out the pads.

---



## WARNING

### POTENTIAL HAZARD

Improperly operating in reverse,

### WHAT CAN HAPPEN

You could hit an obstacle or person behind you, resulting in severe injury.

### HOW TO AVOID THE HAZARD

When you select reverse gear, make sure there are no obstacles or people behind you. When it is safe to proceed, go slowly.

---



## WARNING

## 5. OPERATION WARNINGS

---

### **POTENTIAL HAZARD**

Operating this ATV with improper tires, or with improper or uneven tire pressure.

### **WHAT CAN HAPPEN**

Use of improper tires on this ATV, or operation of this ATV with improper or uneven tier pressure, may cause loss of control, and increases the risk of an accident.

### **HOW TO AVOID THE HAZARD**

Always use the size and type ties specified in the Owner's Manual for this vehicle.

Always maintain proper tire pressure a described in the Owner's Manual.

---



## **WARNING**

### **POTENTIAL HAZARD**

Operating this ATV with improper modifications.

### **WHAT CAN HAPPEN**

Improper installation of accessories or modification of this vehicle may cause changes in handling which in some situations could lead to an accident.

### **HOW TO AVOID THE HAZARD**

Never modify this ATV through improper installation or use of accessories. All parts and accessories added to this vehicle should be genuine or equivalent components designed for use on this ATV; and should be installed and used according to instructions. If you have questions, consult an authorized dealer.

---



## **WARNING**

## 5. OPERATION WARNINGS

---

### **POTENTIAL HAZARD**

Overloading this ATV or carrying or towing cargo improperly.

### **WHAT CAN HAPPEN**

Could cause changes in vehicle handling which could lead to an accident.

### **HOW TO AVOID THE HAZARD**

Never exceed the stated load capacity for this ATV,

Cargo should be properly distributed and securely attached,

Reduce speed when carrying cargo or pulling a trailer.

Allow greater distance for braking.

Always follow the instructions in the Owner's Manual for carrying cargo or pulling a trailer.

---



## **WARNING**

### **POTENTIAL HAZARD**

Riding on frozen lakes and rivers.

### **WHAT CAN HAPPEN**

Severe injury or death can result if the ATV and /or the operator break through the ice.

### **HOW TO AVOID THE HAZARD**

Never ride you ATV on a frozen body of water before you are sure the ice is thick enough and sound enough to support the machine and its operator, as well as the force that is created by a moving vehicle.

---



## **WARNING**

After a rollover or an accident, have a qualified service dealer check the

## 5. OPERATION WARNINGS

---

complete machine including, but not limited to, brakes, throttle and steering for possible damage.

---



### **WARNING**

Safe operation of this rider active vehicle requires good judgement and physical skills. Persons with cognitive or physical disabilities who operate this vehicle have an increased risk of overturns and loss of control which could result in severe injury or death.

---



### **CAUTION**

Keep combustible materials away from exhaust system. Fire may result.

---



### **WARNING**

**HITCH**

## 5. OPERATION WARNINGS

---

### 1).EURO 4, 5



### 2).T3 EFI



#### **Cautions when installing the implement or dragging the ATV**

1. When installing the dragging implement trailer, the engine should stop and the ATV should park at the safety position. Please read implement's or trailer's installing instructions, signs and operating manuals carefully before changing.
2. The operation should be carried out according to the operating manual. Before finishing installing the dragging implement or trailer, it is forbidden to operate the tractor which is installed implement or connected trailer.
3. When connecting the dragging implement or trailer to ATV, it maybe cause personal injury if the person is lack of necessary experience. So the professional should be invited when necessary.
4. The implement should have fallen to ground before people leaving the ATV.
5. People should keep away from the areas between ATV and trailer when ATV is working with trailer.

## **5. OPERATION WARNINGS**

---

### **Front loader and/or backhoe cannot be attached.**

This ATV is not applicable to “forestry application” and “work with crop sprayers”.

### **DANGER**

This ATV is designed not to use front mounted implements such as a front loader, front dozer. Do not operate the ATV with such front mounted implements.

## 6. V.I.N

---

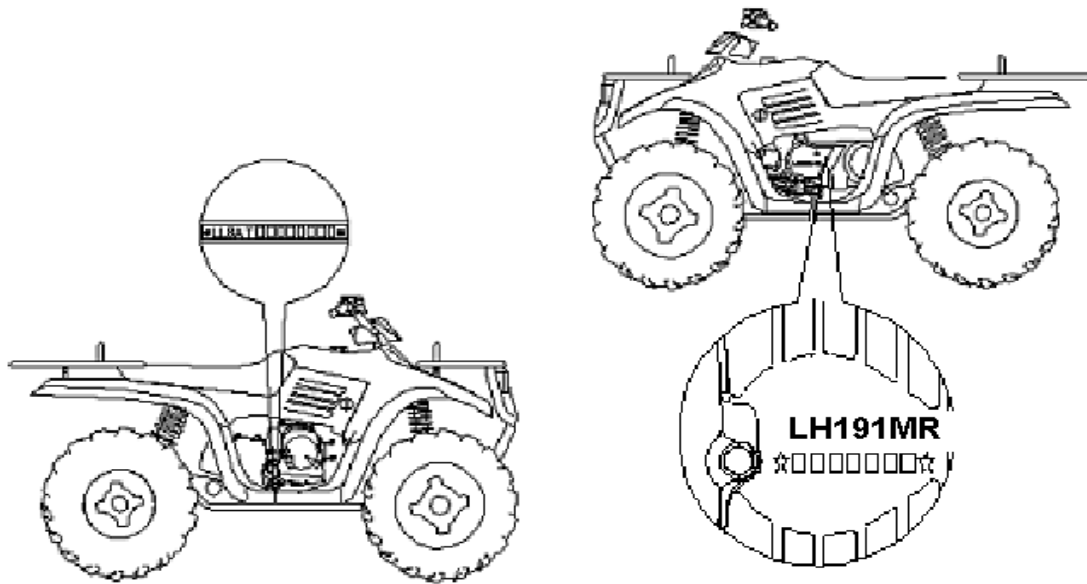

Record these numbers from your ATV in the spaces provided.

1. Frame VIN (found on the lower right side of the frame tube)
2. Engine Serial Number (Left front side of engine crankcase)

**Remove the spare key and store in a safe place.** Your key can be duplicated only by obtaining a key blank and having it cut by mating it with your existing key.

Record Key Number

The vehicle frame and engine serial numbers are important for model identification when registering your vehicle, obtaining insurance or whenever replacement parts are required. In the event your vehicle were stolen these numbers are essential to the recovery and identification of your ATV.



## 7. CONTROL AND PARTS FUNCTIONS

---

### Electrical Switches



**1. Main Switch** -This key switch must be turned clockwise to the “on” position to start the engine.

**2. Hazard Light Switch** –When the switch is pushed to “”, the four signal lights are on and the buzzer is sounding.

**3. Engine Start Button**-To start the engine.

**\*Override Switch (Reverse Speed Limiter)**-Some version of this vehicle is equipped with a reverse speed limiter system. To obtain additional power while backing up, depress the override button. **WARNING:** Never activate the override button while throttle is open as loss of control may result, causing sever personal injury or death.

## 7. CONTROL AND PARTS FUNCTIONS

---

Insert the key into the key switch

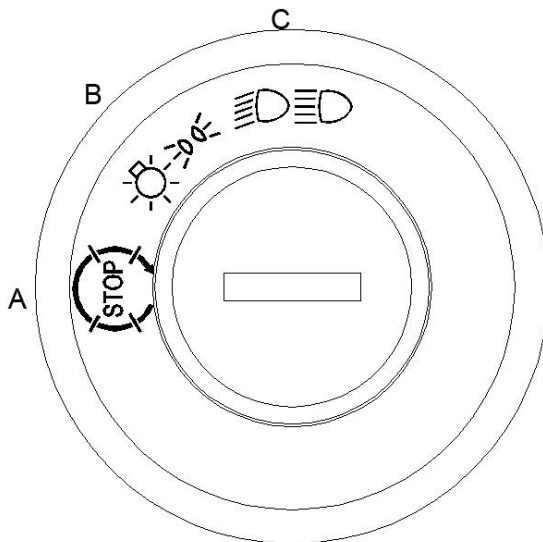

A. "OFF"      B. "ON"      C. "HEAD LIGHT"

"OFF" : Turn the key to this position to stop the engine, switch off all the electrical circuits and remove the key.

"ON" : In this position, the ATV electrical system is connected, the engine can be started and the key cannot be removed.

"HEAD LIGHT" : In this position, the head light will be on.



### WARNING

**Never** turn the key to "OFF" position when the ATV is in motion. Otherwise the electrical system is shut off, which is likely to result in losing control or having an accident. Always make sure that the ATV is stopped before turning the key to "OFF" position.

## 7. CONTROL AND PARTS FUNCTIONS

### LCD Meter for EURO 4, 5

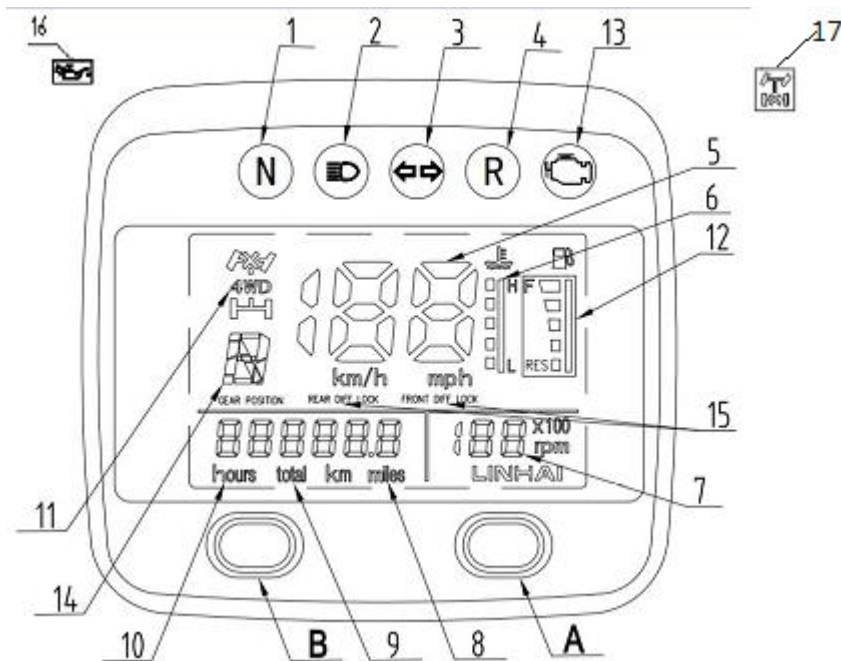

- |                              |                                 |
|------------------------------|---------------------------------|
| 1. Neutral indicator light   | 10. Engine working hour counter |
| 2. High beam indicator light | 11. 2WD/4WD indicator           |
| 3. Turn indicator light      | A: km/ mile selector            |
| 4. Reverse indicator light   | B: hour / distance selector     |
| 5. Speedometer               | 12. Fuel gauge Indicator        |
| 6. Coolant temperature meter | 13. EFI                         |
| 7. Engine rpm meter          | 14. Gear position indicator     |
| 8、9. The odometer            | 15. Rear Diff Lock              |
| 16. Oil alarm lamp           | 17. Rear Diff Lock Swich        |

## 7. CONTROL AND PARTS FUNCTIONS

### LCD Meter for T3

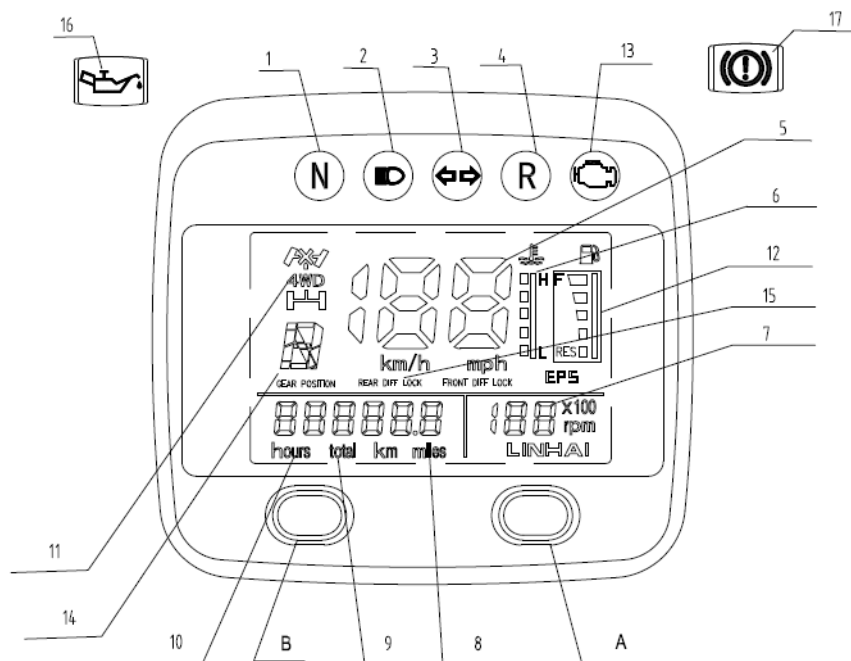

- |                              |                                 |
|------------------------------|---------------------------------|
| 1. Neutral indicator light   | 10. Engine working hour counter |
| 2. High beam indicator light | 11. 2WD/4WD indicator           |
| 3. Turn indicator light      | A: km/ mile selector            |
| 4. Reverse indicator light   | B: hour / distance selector     |
| 5. Speedometer               | 12. Fuel gauge Indicator        |
| 6. Coolant temperature meter | 13. EFI                         |
| 7. Engine rpm meter          | 14. Gear position indicator     |
| 8、9. The odometer            | 15. Rear Diff Lock              |
| 16. Oil alarm lamp           | 17. Brake Fluid indicator       |

## 7. CONTROL AND PARTS FUNCTIONS

---

### Throttle

#### **WARNING**

Do not start or operate an ATV with sticking or improperly operation throttle controls. A stuck or improperly operating throttle could cause an accident resulting in severe injury or death.

Always contact your dealer for service repairs whenever throttle problems arise.

Failure to check or maintain proper operation of the throttle system can result in the throttle lever sticking during riding and cause an accident.

Always check the lever for free movement and return before starting the engine and occasionally during riding.

---

### Throttle Lever

Engine speed and vehicle movement are controlled by pressing the throttle lever. The throttle lever (1)

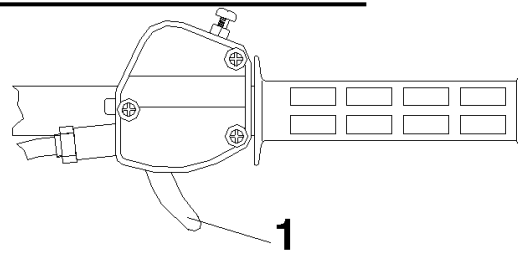

is spring loaded and engine speed returns to idle when the lever is released.

#### **WARNING**

**Washing or operating the scooter in freezing temperatures can result in water freezing in the throttle cable conduit and/or on the throttle mechanism.**

---

This may result in the throttle sticking which can cause the engine to continue to run and result in loss of control.

### Front and Rear Brakes

The brake fluid level should be checked before each ride. The reservoir of hand brake is located on the left side of the handlebar. The reservoir of foot brake is located under the seat. The fluid should be kept between the maximum and minimum marks.

#### **CAUTION**

Once a bottle of brake fluid is opened, use what is necessary and discard the rest. Do not store or use a partial bottle of brake fluid. Brake fluid is hygroscopic, meaning it rapidly absorb moisture from the air. This cause the boiling temperature of the brake fluid to drop, which can lead to early brake

## 7. CONTROL AND PARTS FUNCTIONS

---

fade and the possible of sever injury

---

### Front and Rear Brakes

The front and rear brakes are located on the inside of the right floor board and are operated by the right foot. The front and rear brakes are hydraulically activated disc type brakes which are activated by one pedal only.

Always test brake pedal travel and reservoir fluid level before riding. When squeezed, the pedal should feel firm. Any sponginess would indicate a possible fluid leak or low master cylinder fluid pedal which must be corrected before riding. Contact your dealer for proper diagnosis and repairs.

### WARNING

Never operate the ATV with a spongy feeling brake pedal. operating the ATV with a spongy brake pedal can result in loss of braking. Loss of braking could cause an accident.

---

### Setting the Parking Brake

On independent suspension models:

1. Squeeze the right hand brake

lever two or three times and hold it.

2. Push the park brake lock

into the notches on the lever body. Release the brake lever.

To release the parking brake lock, squeeze the brake lever. It will return to its released position.

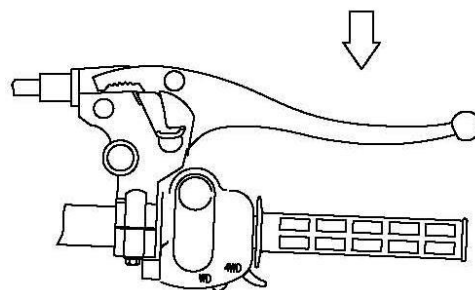

### Important Safeguards

- The parking brake may relax when left on for a long period of time. This could cause an accident.
- **Do not leave the vehicle on a hill depending on the parking brake for**

## 7. CONTROL AND PARTS FUNCTIONS

---

more than five minutes.

- Always block the downhill side of the wheels if leaving the ATV on a hill or park the ATV in a side hill position.

### **WARNING**

Always check to be sure that the parking brake has been disengaged before operating the ATV. An accident could result causing severe injury if the parking brake is left on while the ATV is operated.

---

### Auxiliary Brake

### **WARNING**

**Use caution when applying the auxiliary brake. Do not aggressively apply the auxiliary brake when going forward or the rear wheels may skid and slide sideways causing loss of control.**

---

Auxiliary brake lever

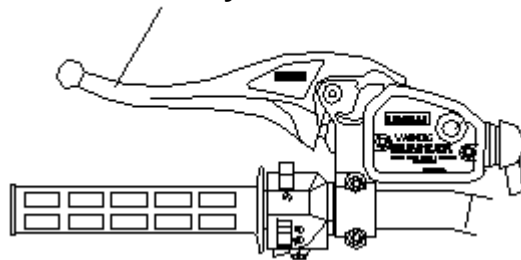

Your ATV has an auxiliary brake provided brake as a safety feature. It is located on the left handlebar and is operated by the left hand. It is intended as a backup to the main brake system, especially if the main system becomes inoperative.

If the rear wheels slide, apply the rear brake with the left hand to some extent. Aggressively applying the rear brake when backing down a hill may cause rear tip over.

## 7. CONTROL AND PARTS FUNCTIONS

---

### Brake Fluid Level

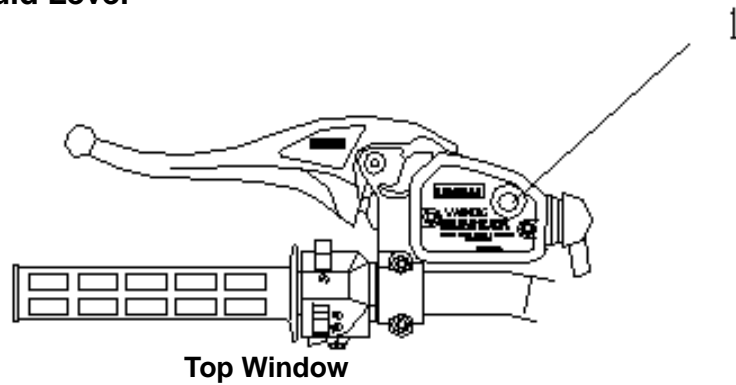

The brake fluid in the master cylinder, which is located on the left handlebar, should be checked before each ride. There is an indicator window (1) on the top of the master cylinder. This window will appear dark when the fluid level is full. When fluid needs to be added, the window will be clear. NOTE: When checking the fluid level, the ATV must be on level ground and the handlebars must be straight. If the fluid level is low add DOT 3 only.

On some models, there is a “side window”, the fluid level can be seen through it, and should be maintained between the indicated “max” and “min” marks on the reservoir.

### Operator's Seat

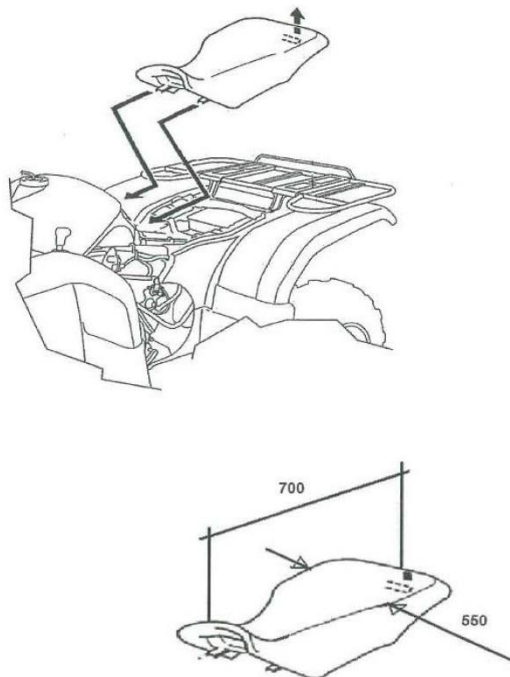



## 7. CONTROL AND PARTS FUNCTIONS

---



### CAUTION

To avoid personal injury: :

1. Make sure that the seat is completely secured.
2. Do not allow any person other than the driver to ride on the tractor.

### Automatic Transmission Gear Selector Operation

The transmission gear selector is located on the left side of the vehicle.

LH500ATV-2D: The transmission selector lever has four positions: low forward ;high forward; neutral and reverse.

LH500ATV-ProMax: The transmission selector lever has five positions: low forward ;high forward; neutral ; reverse and parking.



**NOTE: To extend belt life, use low forward gear in heavy pulling situations and in situations where you are operating below 7mph(11km/h) for extended periods of time.**



### CAUTION

To change gears, stop the vehicle and with the engine idling, move the lever to the desired gear. Shifting gears with the engine speed above idle or while the vehicle is moving could cause transmission damage.

Always place the transmission in gear with the parking brake locked whenever the vehicle is left unattended.

Maintaining shift linkage adjustment is important to assure proper transmission function. Should you experience any shifting problem see your dealer.



### WARNING

**POTENTIAL HAZARD**

## 7. CONTROL AND PARTS FUNCTIONS

---

Engaging a lower gear when the engine speed is too high.

### WHAT CAN HAPPEN

The wheels could stop rotating. This could cause loss of control, an accident and injury. It could also cause engine or drive train damage.

### HOW TO AVOID THE HAZARD

Make certain the engine has sufficiently slowed before shifting to a lower gear.

---

## Engine Cooling System

### Coolant Level

Independent suspension model

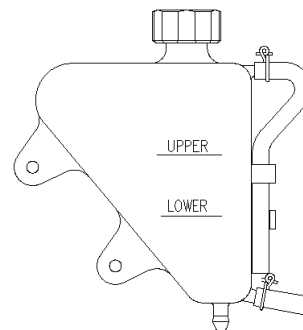

The recovery bottle, located under the seat, must be maintained between the minimum and maximum levels indicated on the recovery bottle.

The engine coolant level is controlled or maintained by the recovery system.

The recovery system components are the recovery bottle, radiator filler neck, radiator pressure cap and connecting hose.

As coolant operating temperature increases, the expanding (heated) excess coolant is forced out of the radiator past the pressure cap and into the recovery bottle. As engine coolant temperature decreases, the contracting (cooled) coolant is drawn back up from the tank past the pressure cap and into the radiator.

**NOTE:** Some coolant level drop on new machines is normal as the system is purging itself of trapped air. Observe coolant levels and maintain as recommended by adding coolant to the recovery bottle. We recommends the use of a 50/50 mixture of high quality aluminum compatible anti-freeze coolant and distilled water.

## 7. CONTROL AND PARTS FUNCTIONS

---

**NOTE:** Always follow the manufacturer's mixing recommendations for the freeze protection required in your area.

### Cooling System

#### **WARNING**

Never remove the pressure cap when the engine is warm or hot. Escaping steam can cause severe burns. The engine must be cool before removing the pressure cap.

---

#### Radiator Coolant Level Inspection

**NOTE:** This procedure is only required if the cooling system has been drained for maintenance and/or repair. However, if the recovery bottle has run dry, the level in the radiator should be inspected and coolant added if necessary.

**NOTE:** Use of a non-standard pressure cap will not allow the recovery system to function properly. If the cap should need replacement contact your dealer for the correct replacement part. To insure that the coolant maintains its ability to protect the engine, it is recommended that the system be completely drain every two years and a fresh mixture of antifreeze and water be added.

Using a funnel, slowly add coolant as necessary through the radiator filler neck.

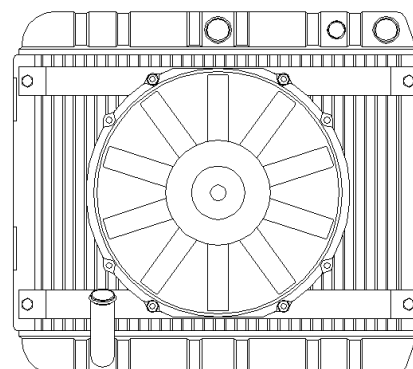

## 7. CONTROL AND PARTS FUNCTIONS

---

### Fuel and Oil system



#### WARNING

Gasoline is highly flammable and explosive under certain conditions.

- Always exercise extreme caution whenever handling gasoline.
  - Always refuel with the engine stopped and outdoors or in a well ventilated area.
  - Do not over smoke or allow open flames or sparks in or near the area where refueling is performed or where gasoline is stored.
  - Do not over fill the tank. Do not fill the tank neck.
  - If you get gasoline on your skin or clothing, immediately wash it off with soap and water and change clothing.
  - Never start the engine or let it run in an enclosed area. Gasoline powered engine exhaust fumes are poisonous and can cause loss of consciousness and death in a short time.
  - Shut off fuel valve whenever the ATV is stored or parked.
- 



#### WARNING

The engine exhaust from this product contains chemicals known, in certain quantities, to cause cancer, birth defects or other reproductive harm.

---

## 7. CONTROL AND PARTS FUNCTIONS

---

### Oil System

The oil tank is located on the right side of the engine .

To check the oil:

1. Set machine on a level surface.
2. Start the engine and let it idle  
for 20-30 seconds.

3. Stop the engine, remove  
dipstick (1) and wipe dry with  
a clean cloth.

4. Put dipstick into the oil tank (don't screw in it), remove it and read the oil  
level.

5. Remove dipstick and check to see that the oil level is between the full and  
add marks(2). Add oil as indicated by the level on the dipstick. Do not overfill.

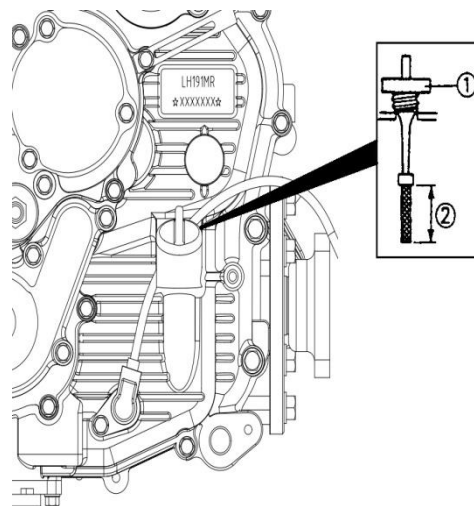

### CAUTION

Use only SAE 15W/40, SG OIL. Never substitute or mix oil brands. Serious engine damage and voiding of warranty can result.

---

## 7. CONTROL AND PARTS FUNCTIONS

### 4 Wheel Drive /Diff Lock System

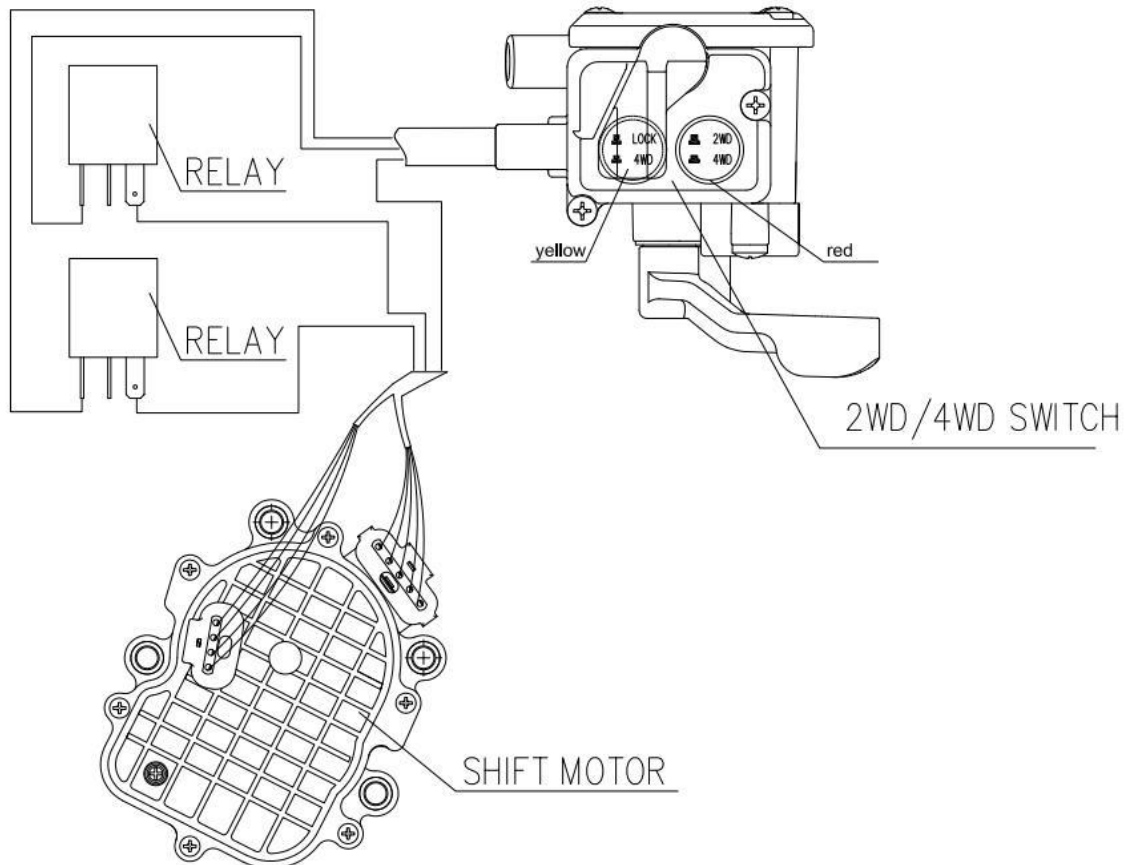

#### CAUTION:

Always shift as the vehicle stop.

#### NOTE:

When shift 2WD/ 4WD or Diff Lock, the mechanics in the front gear box maybe still engaged/ disengaged, the mechanics would finally disengaged/ engaged when rides on a hard surface or rides in reverse.

#### CAUTION

Do not switch on 4WD if the rear wheels are spinning. This may cause severe machine damage. When switch on 4WD, the button will stay in 4WD position but 4WD mechanics maybe still disengaged. Always apply throttle gently and let the wheels move slightly to allow the 4WD mechanics finally engage. The 4WD indicator on the speedometer will come on when 4WD engaged.

## **7. CONTROL AND PARTS FUNCTIONS**

---

### **WARNING:**

Extreme heavy steering is a symptom of malfunction of front gearcase (differential), loss of control could result, even in 2WD position. If you experience any symptoms from the steering, take the ATV to your dealer for inspection and service.

### **NOTE:**

Steering effort increase but remains balanced from left to right.

### **WARNING**

Asymmetrical heavy steering is a symptom of malfunction of one side inner or outer CV joints, loss of control could result, even in 2WD position. If you experience any symptoms from the steering, take the ATV to your dealer for inspection and service.

### **WARNING**

You must inspect your ATV each time before riding to ensure it is in proper working order. If proper inspection is not done, severe injury or death could result.

#### Pre-ride inspection

You can tell if malfunctions in one side CV joints by pulling the handlebar to one side or riding the ATV in low speed. Steering remains balanced from left to right in 2WD and 4WD positions..

## 8. STARTING THE ENGINE

---

### Procedure for Starting a Cold Engine



#### WARNING

Never run an engine in an enclosed area. Carbon monoxide exhaust gas is poisonous and can cause severe injury or death. Always start engines outdoors.



#### CAUTION

You must allow your vehicle adequate warm up time before operating or engine damage could result.

---

1. Place the transmission in neutral and reset the parking brake.
  2. Turn the fuel tank valve to ON.
  3. Sit on the vehicle.
  4. Turn the engine stop switch to RUN.
  5. Turn the ignition key to ON, apply the brake lever and press the starter button.
  6. Do not press the throttle more than 20% while starting the engine.
  7. Activate the starter for a maximum of five seconds, releasing the button when the vehicle starts. If engine does not start, release the starter for another five seconds. Repeat this procedure until engine starts.
- 

### When and how to use the CHOKE

Normal Air Temperature 10° ~35°C

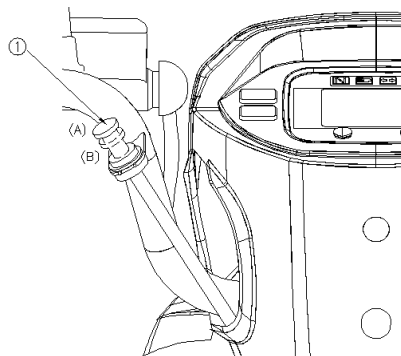

1. Move the choke lever ① left to the fully ON (A) position, if the engine is cold.
2. With the throttle closed, press the starter button.
  - Pressing the electric starter button for more than 5 seconds at a time may



## 8. STARTING THE ENGINE

---

casue the starter to overheat and damage the starter. Release the starter button for approximately 10 seconds before pressing it again.

3. Immediately after the engine starts, operate the choke knob to keep fast idle.
4. Continue warming up the engine until it runs smoothly and responds to the throttle with the choke knob in the fully OFF (B) position.
5. If idling is unstable, open the throttle slightly.

### High Air Temperature 35°C

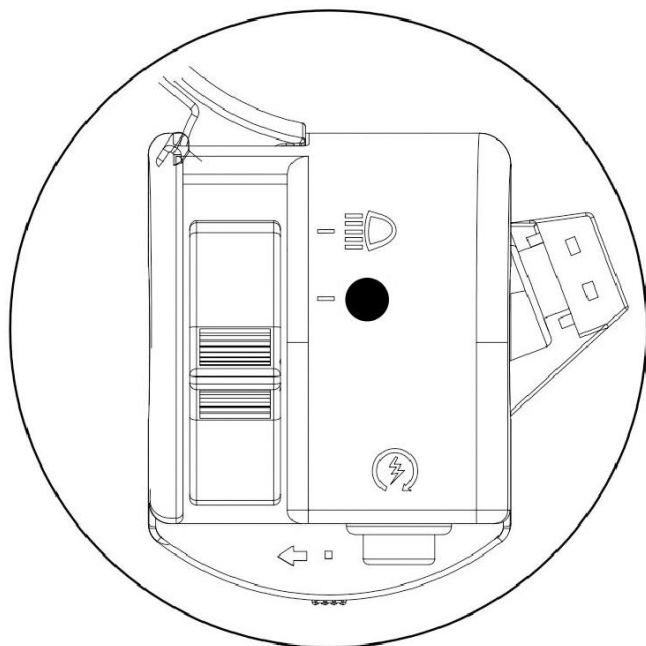

For LH500ATV-D (EFI MODEL)

### Procedure for Starting a Cold Engine



Never run an engine in an enclosed area. Carbon monoxide in the exhaust gas is poisonous and can cause severe injury or even death. Always start engines outdoors.

---



You must allow your vehicle adequate warm up time before operating or engine damage could result.

## **8. STARTING THE ENGINE**

---

1. Place the transmission in neutral and reset the parking brake.
2. Sit on the vehicle.
  1. Turn the engine stop switch to RUN.
  2. Turn the ignition key to ON, apply the brake lever and press the starter button.
  3. When the temperature is cold, can press the throttle a little open , but do not press the throttle more than 20% while starting the engine.
  4. Activate the starter for a maximum of five seconds, releasing the button when the vehicle starts. If engine does not start, release the starter for another five seconds. Repeat this procedure until engine starts.

## 9. VEHICLE BREAK-IN PERIOD

---

The break-in period for your new ATV is defined as the first 50 hours of operation. No single action on your part is as important as a proper break in period. Careful treatment of new engine will result in more efficient performance and longer life for the engine. Perform the following procedures carefully.



### CAUTION

Do not operate at full throttle or high speeds for extended periods during the break-in period. Excessive heat can build up and cause damage to close fitted engine parts.

**Please set a limit to half throttle during the break-in periods.**

1. Locknut 2. Adjuster

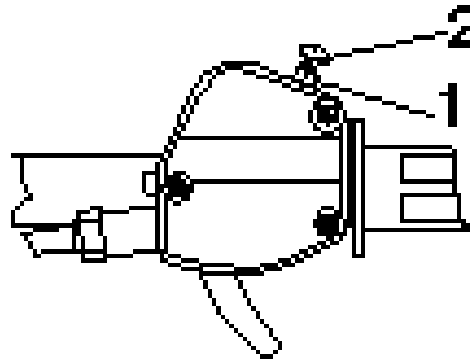

- 
1. Fill fuel tank.
  2. Check oil reservoir level indicated on dipstick. Add oil if necessary.
  3. Drive slowly at first. Select an area which is open and will give you room to familiarize yourself with vehicle operation and handling.
  4. Vary the throttle positions. Do not operate at sustained idle.
  5. Perform regular checks on fluid levels, controls and all important areas on the vehicle as outlined earlier on the daily pre-ride inspection checklist found in "4.daily pre-ride inspection".
  6. Don't pull loads.
  7. Break in oil and filter. Change at 20 hours or 500 miles/800km.

# **10. RIDING GEAR**

---

## **Safe Riding Gear**

Always wear clothing suitable to the type of riding you are doing. ATV riding requires special protective clothing which will make you feel more comfortable and reduce chances of injury.

### **1. Helmet**

Your helmet is the most important piece of protective gear for safe riding. A helmet can prevent a severe head injury.

Select an approved helmet.

### **2. Eye Protection**

A pair of goggles or helmet face shield offer the best protection for your eyes.

### **3. Gloves (off-road style)**

### **4. Boots**

A pair of strong over the calf type boots with heels, such as moto-cross boots.

### **5. Clothing**

To protect your body, long sleeves and pants should always be worn. Riding pants with kneepads, a jersey and shoulder pads provide the best protection.

## 11. RIDING

---



### WARNING

The engine rpm limiter will work at 7500rpm, this may cause excessive fuel to build in the exhaust, and ignited by the catalyst in the muffler, MAY RESULT IN THE MUFFLERS OVERHEATING AND FIRE RISK.

Always reduce throttle when the engine reach top rpm, avoid the engine popping.



### WARNING

RIDING THIS ATV WITH POOR ENGINE TUNING MAY RESULT IN THE MUFFLERS OVERHEATING AND FIRE RISK. If the motor is running roughly, stop the ATV immediately and have it serviced by the authorized dealer.



### WARNING

You must inspect you ATV each time before riding to ensure it is in proper working order. If proper inspection is not done, severe injury or death could result.

See“4.DAILY PRE-RIDE INSPECTION”

---

1. Sit upright with both feet on footrests and both hand on the handlebars.
2. After starting the engine and allowing it to warm up, shift the transmission into gear.
3. Check your surroundings and determine your path of travel.
4. Release the parking brake.
5. Slowly depress the throttle with your right thumb and begin driving .Vehicle speed is controlled by the amount of throttle opening.
6. Drive slowly, practice maneuvering and using the throttle and brakes on level surfaces

# 11. RIDING

---

## Making turns

### Practice making turns at slow speeds

This ATV is equipped with a solid rear axle which drives both rear wheels equally at all times. This means that the wheel on the outside of the turn must travel a greater distance than the inside wheels when turning and the inside tire must slip traction slightly. To turn, steer in the direction of the turn leaning your upper body to the inside of the turn while supporting your weight on the outer footrest. This technique alters the balance of traction between the rear wheels allowing the turn to be made smoothly. The same leaning technique should be used for turning in reverse



## WARNING

Avoid turning at sharp angles in reverse as tip over and severe injury may result.

---

# 11. RIDING

---

## Riding on slippery surfaces

Whenever riding on slippery surface such as wet trails or loose gravel, or during cold freezing weather, special attention must be paid to prevent vehicle turnover.

### Always:

1. Slow down when entering slippery areas.
2. Maintain a high level of alertness, reading the trail and avoiding quick, sharp turns which can cause skids.
3. Correct a skid by turning the handlebars in the direction of the skid and shifting your body weight forward.
4. Never apply brakes during a skid. Complete loss of ATV control can result.
5. Do not operate on excessively slippery surfaces.
6. Always reduce speed and use additional caution.



### **WARNING**

Failure to exercise care when operating the ATV on slippery Surfaces can be dangerous.

Loss of tire traction and vehicle control can result in an accident, including an overturn.

---

# 11. RIDING

---

## Traveling Uphill



### WARNING

Exercise extreme caution when traveling in hilly terrain.

Braking and handling are greatly affected. Loss of vehicle control or overturning of the ATV could occur causing severe injury or death.

---

### Whenever traveling uphill always travel straight uphill and:

1. Avoid steep hills (15%maximum).
2. Keep both feet on the footrests.
3. Transfer you weight forward.
4. Proceed at a steady rate of speed and throttle opening.
5. Remain alert and be prepared to take emergency action. This may include quick dismounting of the ATV.

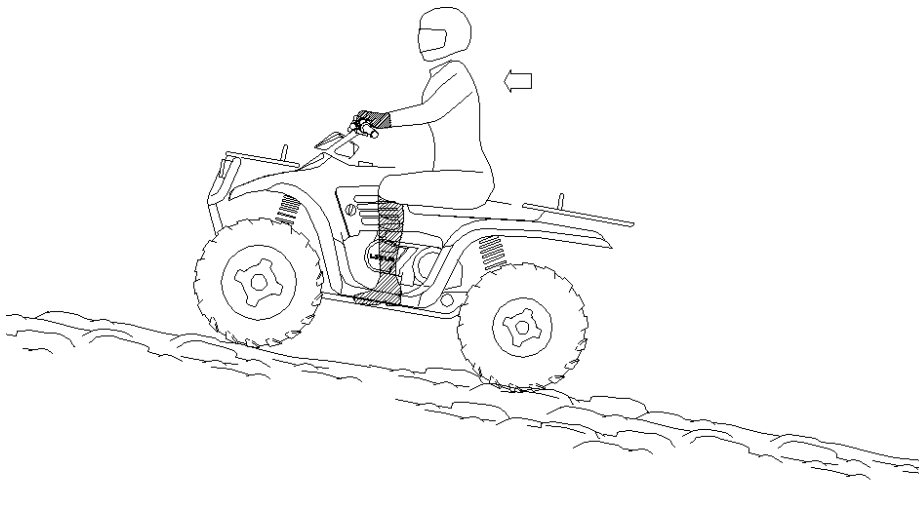



# 11. RIDING

---

## Sidehilling

Side hilling your ATV is one of the most dangerous types of riding and should be avoided. If you do enter into a situation where sidehilling is necessary, always:

1. Slow down.
2. Lean into the hill transferring your upper body weight toward the hill while keeping your feet on the footrests.
3. Steer slightly into the hill to maintain vehicle directions.

If vehicle begins to tip, quickly turn the front wheel downhill, if possible, or dismount on the uphill side immediately!



## WARNING

Improperly crossing hills or turning on hills can be dangerous. Loss of vehicle control or overturning of the ATV could occur causing severe injury or death.

---

# 11. RIDING

---

## Traveling Downhill.

**Whenever descending a hill, always:**

1. Drive directly downhill.
2. Transfer your weight to the rear of the vehicle.
3. Slow down.
4. Apply the brakes slightly to aid in slowing.

Familiarize yourself with the auxiliary rear brake pedal and its use in the event loss of normal service brakes occurs.



## WARNING

Do not travel at excessive speeds. It is dangerous and can cause loss of vehicle control and tipping, resulting in severe injury or death.

---

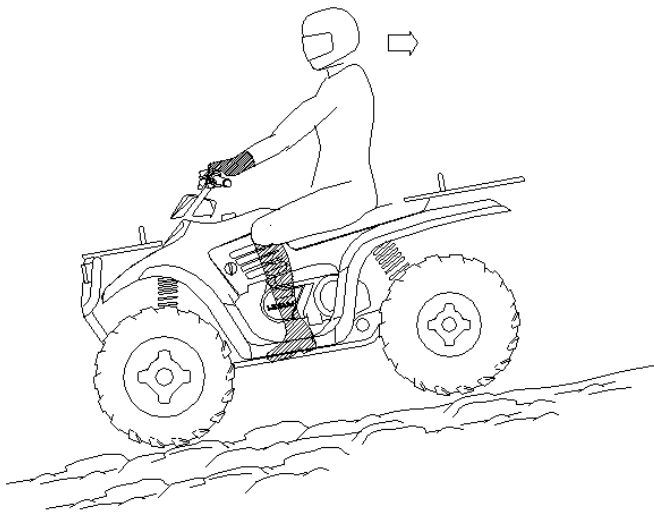

## Turning Around On a Hill

## 11. RIDING

---

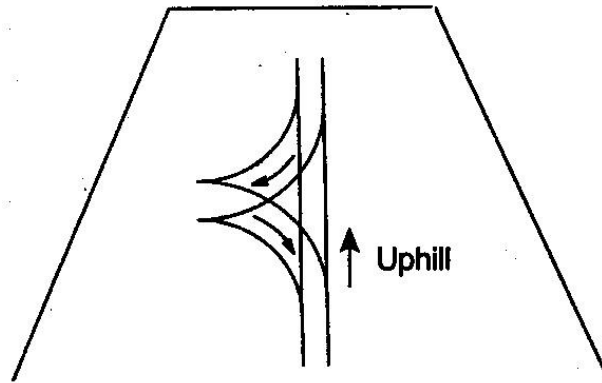

**If the ATV stalls while climbing a hill, never back it down the hill! One maneuver which can be used when it is necessary to turn around while climbing a hill is the K-turn.**

1. Stop and lock the parking brake while maintaining body weight uphill.
2. Leave transmission in forward and shut off engine.
3. Dismount on left or uphill side of ATV.
4. Staying uphill of ATV, turn handlebars full left (while facing front of ATV).
5. While holding service brake, release parking brake lock and slowly allow ATV to roll around to your right until ATV is pointing across the hill or slightly downward.
6. Lock the parking brake and remount ATV from the uphill side, maintaining body weight uphill.
7. Restart engine with transmission still in forward, release parking brake, and proceed slowly, controlling speed with the service brake, until ATV is on reasonably level ground.



### **WARNING**

Avoid climbing steep hills. Loss of vehicle control or overturning of the ATV could occur resulting in severe injury or death.

---

### **Crossing Streams**

## 11. RIDING

---

Your ATV can operate through water up to maximum recommended depths is 8 inch. Before fording streams always:

1. Determine water depths and current.
2. Choose a crossing where both banks have gradual inclines.
3. Proceed slowly, avoiding rocks and obstacles if possible.
4. After crossing, dry the brakes by applying light pressure to the lever until braking action is normal.



### CAUTION

**Never operating the ATV through deep or fast flowing water.**

---

**NOTE:** After running the vehicle in water, it is critical your machine is serviced as outlined in the maintenance chart see “**16.maintenance**”.The following areas need special attention: engine oil, transmission oil, rear gear case, and all grease fittings.

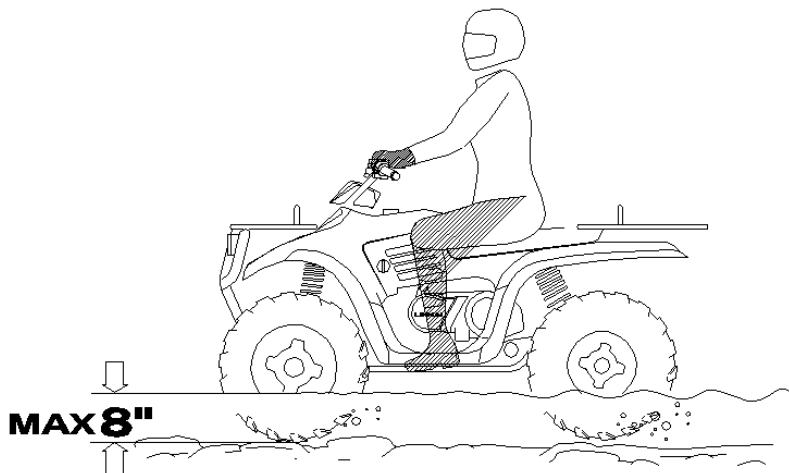

## 11. RIDING

---



### CAUTION

**If your ATV becomes immersed, take it to your dealer before starting the engine. Major engine damage can result if the machine is not thoroughly inspected.**

If it is impossible to take it to a dealer before starting, follow the steps outlined below.

- Move the ATV to dry land or at the very least, to water depth not more than 8 inch (200mm).
- Remove the spark plug.
- Turn the engine over several times with electric start.
- Dry the spark plug and reinstall or replace with a new plug.
- Attempt to start the engine. If necessary repeat the “drying” procedure.
- Take the machine to your dealer for service as soon as possible whether you succeed in starting it or not.

If water has been ingested into the CVT system, take the ATV to your dealer for service as soon as possible.

# 11. RIDING

---

## Trail Obstacles

### Keep Alert!

Look ahead and learn to read the trail as you ride. Stay on the right side of the trail, if possible, and be constantly alert for hazards such as logs, rocks and low hanging branches.



### WARNING

Not all obstacles are visible. Travel with caution on trails severe injury or death can vehicle comes in contact with a hidden obstacle.

---

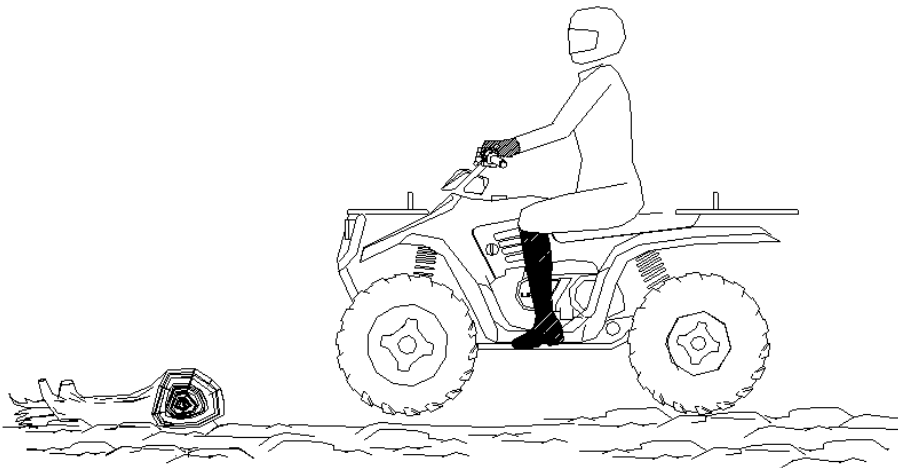

## 11. RIDING

---



### WARNING

#### Backing your ATV can be dangerous!

You could hit an obstacle or person behind you; or the vehicle could tip over rearward on a steep incline causing severe injury or death.

---

#### Backing up

1. Avoid backing up on steep inclines.
2. Always back slowly.
3. When in reverse, apply the brakes lightly for stopping.
4. Avoid turning at sharp angles in reverse.
5. Never open the throttle suddenly while backing.

**NOTE:** This ATV is equipped with a reverse speed limiter. Do not operate at wide open throttle. Only open the throttle enough to maintain a desired speed.



### CAUTION

Opening the throttle more than required may cause excessive fuel to build in the exhaust, resulting in engine popping and/or engine damage.



### WARNING

Opening the throttle more than required may cause excessive fuel to build in the exhaust, and ignited by the catalyst in the muffler, **MAY RESULT IN THE MUFFLERS OVERHEATING AND FIRE RISK.**

Never ride with engine popping more than 1 minutes.

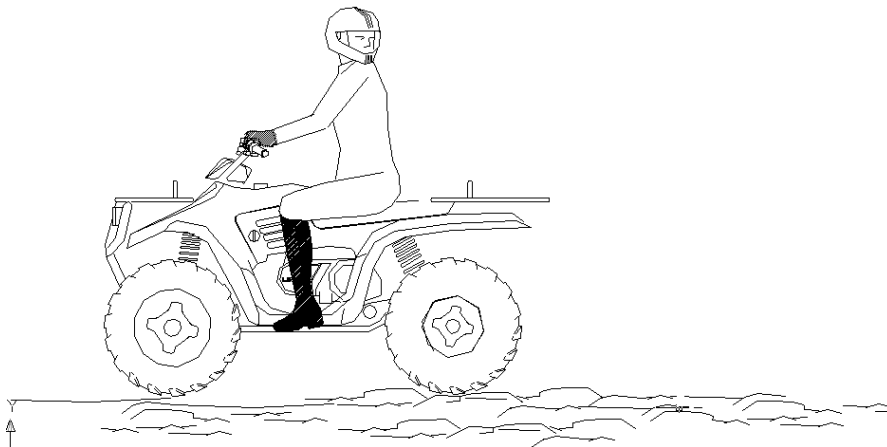

# 11. RIDING

---

## Parking on an incline

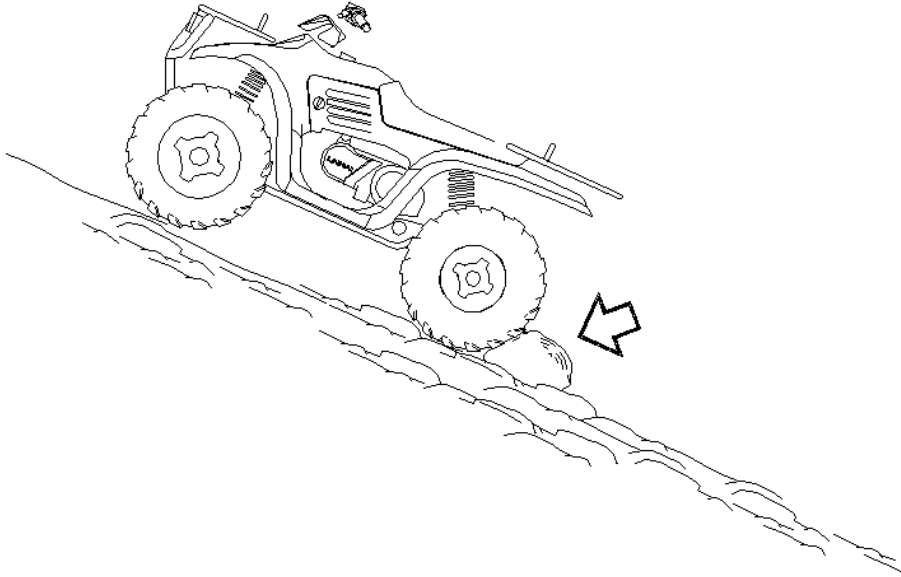

### Whenever the vehicle is parked

1. Turn the engine off.
2. Set the parking brake. Confirm the ATV does not move. Engage the PARK gear.
3. Avoid parking on an incline. If it is necessary to park on an incline, always block the rear wheels on the down hill side as shown above.
4. Do not leave the ATV on a hill depending on the parking brake for more than five minutes.



## 12. CVT SYSTEM

---



### WARNING

The CVT system rotates at high speeds, creating large amounts of force on clutch components. However, as the owner you have the following responsibilities to make sure this system remains safe:

- Do not modify any component of the CAT system. Doing so may reduce its strength so that a failure may occur at high speeds. Any modification will cause the system to be out of balance, creating vibration and additional loads on components.
- Routine maintenance is the responsibility of the owner. Always follow recommended maintenance procedures. See your dealer!
- The CVT housing must be securely in place during operation.

Failure to comply with this warning can result in severe injury or death.

---

### **Low Range Use May Reduce CVT Operating Temperatures**

The basic operation of the CVT system is dependent on engine speed and vehicle torque requirements. As engine speed increased, the force exerted on the movable drive sheave by the fly-weights also increases. This, in turn, increases the amount of “pinch” applied to the drive belt. Similarly, if the engine speed decreases, the amount of centrifugal force decreases, reducing the amount of belt “pinch.”

## **12. CVT SYSTEM**

---

On this ATV, the approximate gear ratio difference between high and low range is 1:1.88. This difference in gearing affects the operation of the CVT, especially at speeds less than 7 MPH, due to the system's dependence on engine speed.

By switching to low range while operating at low ground speeds, the air temperature in the clutch will be reduced. Reducing the temperature inside the clutch cover extends the life of the CVT components (belt, cover, etc.).

### **When To Use Low Range**

The following lists provide a guideline for when to use low range rather than high.

#### **Low Range**

- Basic operation at speeds less than 7 MPH (11km/h)
- Heavy pulling
- Riding through rough terrain (swamps, mountains, etc.) at low ground speeds

#### **High Range:**

- Basic operation at speeds greater than 7 MPH (11km/h)
- High ground speeds

## 13. CARRYING LOADS

---

Your ATV has been designed to carry a certain amount of load. CARGO WEIGHT should be evenly distributed ( $\frac{1}{3}$  on the front and  $\frac{2}{3}$  on the rear ) and mounted as low as possible. When operating over rough or hilly terrain, reduce speed and cargo to maintain stable driving conditions. Never exceed the weights specified in your Owner's Manual.

Maximum trailer weight-396 lbs (180kg) on level ground. Maximum vertical hitch weight-22 lbs (10kg).

Improper loading of the front rack can obstruct the headlight beam, reducing night visibility. Do not obstruct the headlight beam with cargo.

**Use of low forward gear is recommended in heavy pulling situations to extend belt life.**



### WARNING

Correct loading of this vehicle is necessary to maintain proper stability and operating characteristics. Overloading or incorrect positioning of the load affects the vehicle's turning, stopping distance and stability. Failure to follow loading requirements could cause severe injury or death.

---

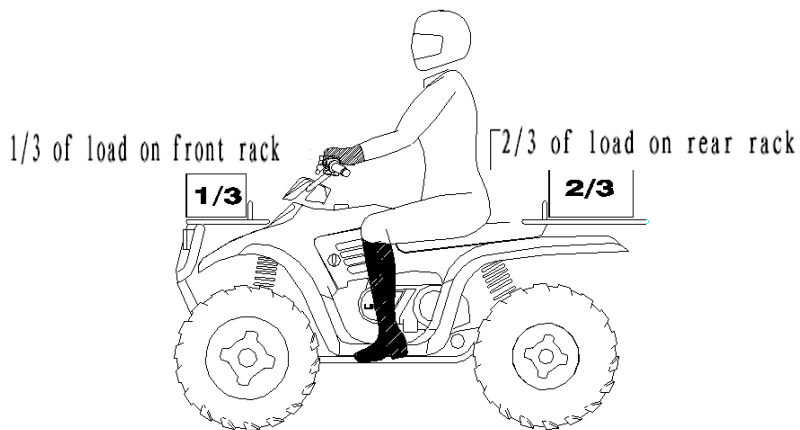

### Important Safeguards

To reduce risk of injury or machine damage when carrying loads, read and follow the warnings listed below:

## **13. CARRYING LOADS**

---

- **REDUCE SPEED AND ALLOW GREATER DISTANCE FOR BRAKING WHEN CARRYING CARGO.**
- **CARGO WEIGHT DISTRIBUTION** should be 1/3 on the front rack and 2/3 on the rear rack. When operating over rough or hilly terrain, reduce speed and cargo to maintain stable driving conditions. Carrying loads on one rack only increases the possibility of vehicle tip over.
- **HEAVY LOADS CAN CAUSE BRAKING AND CONTROL PROBLEMS.** Use extreme caution when applying brakes with a loaded vehicle. Avoid terrain or situations which may require backing downhill.
- **ALL LOADS MUST BE SECURED BEFORE MOVING VEHICLE.** Unsecured loads can create unstable operating condition, which could result in loss of control of vehicle.
- **LOADS MUST BE CARRIED AS LOW ON THE RACKS AS POSSIBLE .** Carrying loads high on the racks raises the center of gravity of the vehicle and creates a less stable operating condition. When cargo loads are carried high on the racks, the weight of the loads must be reduced to maintain stable operating conditions.
- **OPERATE ONLY WITH STABLE AND SAFELY ARRANGED LOADS.** Avoid handling off-centered loads which cannot be centered. Always attach the tow load to the hitch point designated for your ATV.
- **EXTREME CAUTION MUST BE USED.** Avoid operating with loads extending over the rack sides. Stability and maneuverability may be adversely affected, causing the vehicle to overturn.
- **DO NOT BLOCK THE HEADLIGHT/TAILLIGHT AND THE REFLECTORS** when carrying loads on the racks.
- **DO NOT TRAVEL FASTER THAN THE RECOMMENDED SPEEDS.** Vehicle should never exceed 10 mph (16km/h) while towing a load on a level grass surface. Vehicle speed should never exceed 5 mph(8km/h) when towing loads in rough terrain, while cornering, or while ascending or descending a hill

## 13. CARRYING LOADS

---

### Use A Safety Chain

- A safety chain will help control drawn machinery should it separate from the tractor drawbar.
- Use a chain with the strength rating equal to or greater than the gross weight of the towed machinery.
- Attach the chain to the tractor drawbar support or other specified anchor location. Allow only enough slack in the chain to permit turning.
- Do not use safety chain for towing.

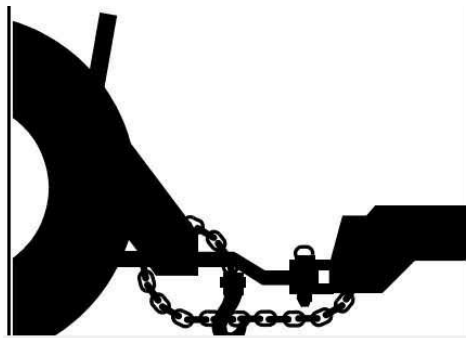

## 14. BATTERY

---



### WARNING

Whenever removing the battery, disconnect the negative (black) cable first. When reinstalling the battery, connect the negative (black) cable last or an explosive situation could result causing serious injury or death.

---



### WARNING

Battery electrolyte is poisonous. It contains sulfuric acid. Serious burns can result from contact with skin, eyes or clothing. Antidote:

**External:** Flush with water.

**Internal:** Drink large quantities of water or milk. Follow with milk of magnesia, beaten egg, or vegetable oil. Call physician immediately.

**Eyes:** Flush with water for 15 minutes and get prompt medical attention.

Batteries produce explosive gases. Keep sparks, flame, cigarettes, etc. away. Ventilate when charging or using in an enclosed space. Always shield eyes when working near batteries. **KEEP OUT OF REACH OF CHILDREN.**

---

### Replenishing the Battery Fluid

A poorly maintained battery will deteriorate rapidly. Check the battery fluid level often. The fluid level should be kept between the upper and lower level marks.

To refill use only distilled water.

Tap water contains minerals which are harmful to a battery.

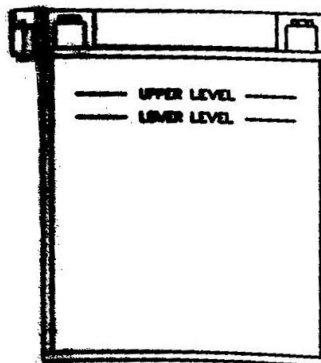

# 14. BATTERY

---

## Battery Removal

1. Disconnect hold down straps holding the electrical box and battery in position and remove battery cover.
2. Remove the battery vent tube from the battery.
3. Disconnect the black (negative) battery cable first.
4. Disconnect the red(positive) battery cable next.
5. Lift the battery out of the ATV, being careful not to tip it sideways and spill electrolyte.



### CAUTION

If electrolyte spills, immediately wash it off with a solution of one tablespoon baking soda and one cup water to prevent damage to the ATV.

---

## Battery Installation and Connections



### WARNING

To avoid the possibility of explosion, always connect battery cables in the order specified. Red (positive) cable first; black (negative) cable last. An exploding battery can cause serious injury or death.

---

Battery terminals and connections should be kept free of corrosion.

If cleaning is necessary, remove the corrosion with a stiff wire brush. Wash with a solution of one tablespoon baking soda and one cup water. Rinse well with tap water and dry off with clean rags. Coat the terminals with dielectric grease or petroleum jelly. Be careful not to allow cleaning solution or tap water into the battery.

1. Set the battery in its holder.
2. Install the battery vent tube. It must be free from obstructions and securely installed. If not, battery gases could accumulate and cause an explosion. The tube should be routed away from the frame and body to prevent corrosion. Avoid skin contact with electrolyte, severe burns could result.
3. First connect and tighten the red (positive) cable.
4. Second connect and tighten the black (negative) cable.

## 14. BATTERY

---

5. Reinstall battery cover and attach the hold down strap.
6. Verify that cables are properly routed.

### NOTE:

- When you ATV is placed in storage for one months or more, the battery should be removed, charged to proper level, and stored in a cool dry place.
- Before reusing, take the battery to your dealer for testing and recharging. Power plug leads may need to be bent down so that battery cover may be installed.
- When installing a new battery, make certain it is fully charged prior to it is initial use. Using a new battery that has not been fully charged can damage the battery resulting in a shorter life of the battery, It can also hinder vehicle performance.



### CAUTION

Your ATV is equipped with a 18 Ah Battery. This may no be sufficient to provide power for optional equipment. When installing optional equipment please upgrade your battery as necessary. See your dealer for the proper battery.

---



# 15. EXHAUST SYSTEM

---

## SYSTEM REGULATION

### TAMPERING WITH NOISE CONTROL SYSTEM PROHIBITED!

**CAUTION:** Exhaust system components are very hot during and after use of ATV.

- Do not touch exhaust system components. Serious burns can result. Be especially careful when traveling through tall grass. The potential for fire exists

### Spark Arrestor

The exhaust pipes must be periodically purged of accumulated carbon as follows:

1. Remove the arrestor screw ① located on the bottom of the muffler and remove the temperature detector located on the surface of the muffler, pull out the arrestor (the mesh)②.
2. Clean the arrestor or replace it.



## WARNING

When cleaning the spark arrestor, you must follow the safe guards listed below to avoid serious injury.

- Do not perform this operation immediately after the engine has been run because the exhaust system becomes very hot.
- Keep combustible materials away from exhaust system. Fire may result.

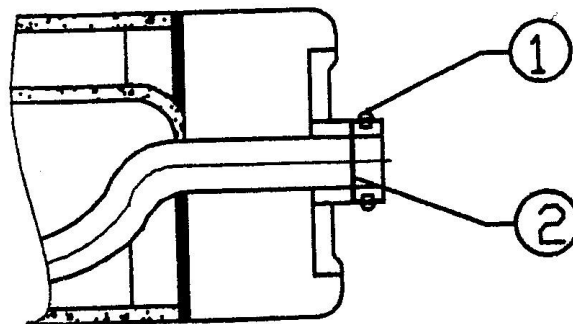

## 15. EXHAUST SYSTEM

---

### Catalyst

There is catalyst inside the muffler on all Europe models and some U.S. models.



### WARNING

The engine rpm limiter will work at 7500rpm, this may cause excessive fuel to build in the exhaust, and ignited by the catalyst in the muffler, **MAY RESULT IN THE MUFFLERS OVERHEATING AND FIRE RISK.**

Always reduce throttle when the engine reach top rpm, avoid the engine popping.

## 16. MAINTENANCE

---



### CAUTION

Due to the nature of the adjustments marked with a D on the following chart, it is recommended that service be performed by an authorized dealer.

---

- More often under severe use, such as dirty or wet conditions to purge water or dirt contamination from grease fittings and other critical components.

### Periodic Maintenance Schedule

Careful periodic maintenance will help keep your vehicle in the safest, most reliable condition. Inspection, adjustment and lubrication intervals of important components are explained in the following chart on the following pages.

Maintenance intervals are based upon average riding conditions and an average vehicle speed of approximately 10 miles per hour. Vehicles subjected to severe use, such as operation in wet or dusty areas, should be inspected and serviced more frequently.

Inspect, clean, lubricate, adjust or replace parts as necessary.

**NOTE:** Inspection may reveal the need for replacement parts. Always use genuine parts available from your dealer.

Service and adjustments are critical. If you are not familiar with safe service and adjustment procedures, have a qualified dealer perform these operations.

## 16. MAINTENANCE

	Item	Hours	When	Remarks
	Brake System	Pre-ride	Pre-ride	Pre-ride inspection item
	Auxiliary Brake	Pre-ride	Pre-ride	Pre-ride inspection item
	Tires	Pre-ride	Pre-ride	Inspect daily, pre-ride inspection item
	Wheels	Pre-ride	Pre-ride	Pre-ride inspection item
	Frame nuts, bolts fasteners	Pre-ride	Pre-ride	Pre-ride inspection item
●	Air Filter-Pre-Cleaner	Daily	Daily	Inspect-Clean
	Coolant/Level Inspection	Daily	Daily	Replace engine coolant Every one year
●	Air Box Sediment Tube	Daily	Daily	Drain deposits whenever visible
	Headlamp Inspection	Daily	Daily	Check operation daily; apply dielectric grease to connector when replaced
	Tail lamp inspection	Daily	Daily	Check operation daily; apply dielectric grease to socket when replaced
●	Air Filter-Main Element	Weekly	Weekly	Inspect –Replace if necessary
	Battery	20 hrs	Monthly	Check/clean Terminals; check fluid level
D	Brake pad wear	10 hrs	Monthly	Inspect periodically
●	Rear Gear case Oil	100 hrs	Monthly	Check monthly and change annually
●	Front Gear case Oil ( Only for 4WD)	100 hrs	Monthly	Firstly at 300km, after every 1000km
	Engine Cylinder Head and Cylinder Base Fasteners	25 hrs	300km	Inspection every 1000km re-torque required at first service only!
●	General Lubrication	50 hrs	300km	Inspection every 1000km
●	Engine Oil-Level/Change	30 hrs	1000km	Check Level Daily; Break in Service at 300km. Change oil more often in cold weather use.

## 16. MAINTENANCE

	Item	Hours	When	Remarks
●	Oil Filter	50 hrs	1000km	Inspect-clean. Break in Service at 300km
	Engine breather hose	100 hrs	1000km	Inspect
D	Throttle Cable	50 hrs	1000km	Inspect –adjust, lubricate, replace if necessary; pre-ride inspection item
	Coolant strength	100 hrs	1000km	Inspect strength seasonally
	Shift linkage	50 hrs	1000km	Inspect, adjust
D	Drive belt	50 hrs	1000km	Inspect, replace if Necessary. Break in Service at 300km
●	Steering	50 hrs	1000km	Inspect daily, lubricate
●	Front Suspension	50 hrs	1000km	Inspect-lubricate, tighten fasteners
●	Rear Suspension	50 hrs	1000km	Inspect, tighten fasteners
	Spark Plug	100 hrs	1000km	Inspect-replace if necessary
D	Ignition Timing	100 hrs	1000km	Inspect and adjust as needed
D	Fuel System	100 hrs	1000km	Check for leaks at tank cap, lines, fuel valve, filter. Replace lines every one year
D	Fuel Filter	100 hrs	1000km	Replace annually
	Radiator	100 hrs	1000km	Inspect/clean external surface
	Cooling System hoses	50 hrs	1000km	Inspect/replace if necessary
	Spark arrestor	10 hrs	1000km	Clean out-replace if necessary
D	Clutches (drive and driven)	25 hrs	1000km	Inspect, clean. Break in Service at 300km
	Engine mounts	25 hrs	1000km	Inspect. Break in Service at 300km
D	Valve clearance	100 hrs	3000km	Inspect/adjust
D	Shift selector box (H/L/R/N)	200 hrs	2000km	Change grease every two years
D	Brake fluid	200 hrs	24 months	Change every two years
	Idle Speed	As required	As required	Adjust
D	Toe adjustment	As required	As required	Periodic inspection, adjust when parts are

# 16. MAINTENANCE

				replaced
	Headlight Aim	As required	As required	Adjust if necessary

## Lubrication Recommendations

Item	Lube Rec	Method	Frequency
1. Engine Oil	SAE10W-40/SN	Add to proper level on dipstick	Check level daily
2.Brake Fluid	DOT 3 Or DOT 4	Maintain level Between fill lines. See "6.BRAKES"	As require; change every two years or 200 hours
4.Rear Gear case oil	SAE GL-4 85W/90	See "16.MAINTENANCE/Rear Gear case Lubrication"	Change annually or at 100 hours
5.Front Gear case oil	SAE GL-4 85W/90	See "16.MAINTENANCE/Rear Gear case Lubrication"	Change annually or at 100 hours

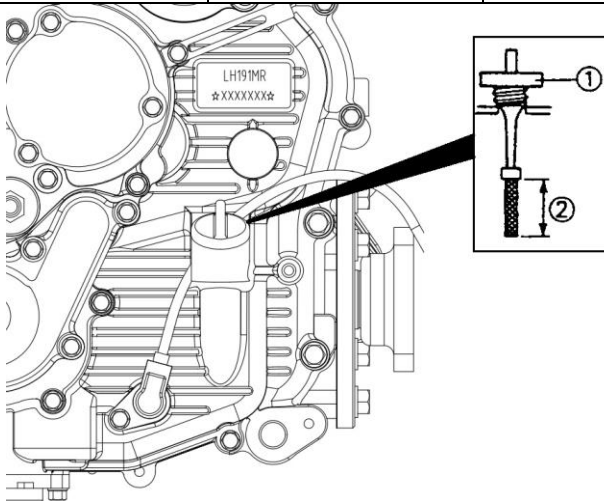

# 16. MAINTENANCE

## 4. Rear Gear

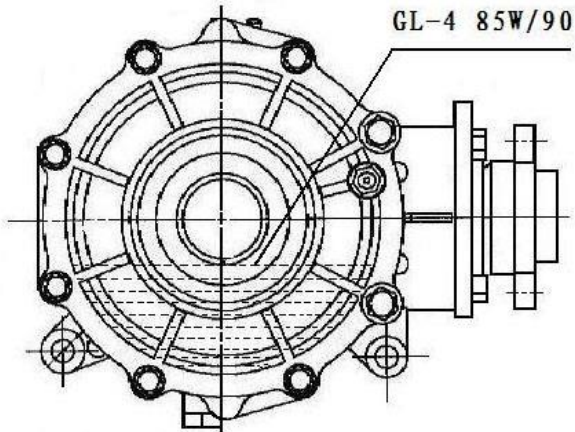

## 4. Diff Rear Gear

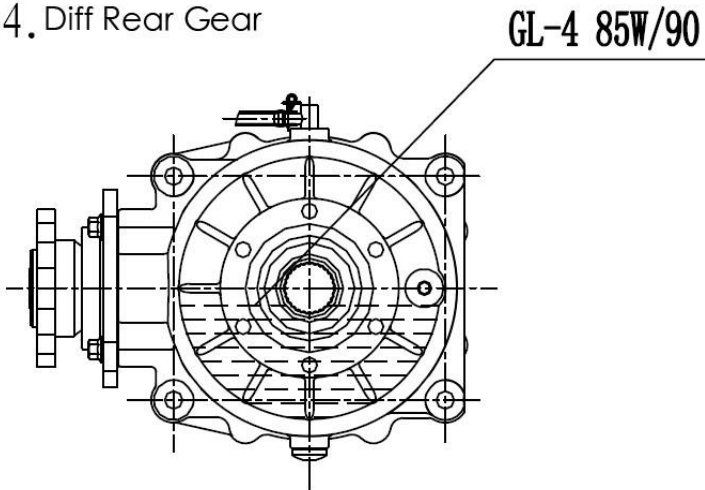

## 5.

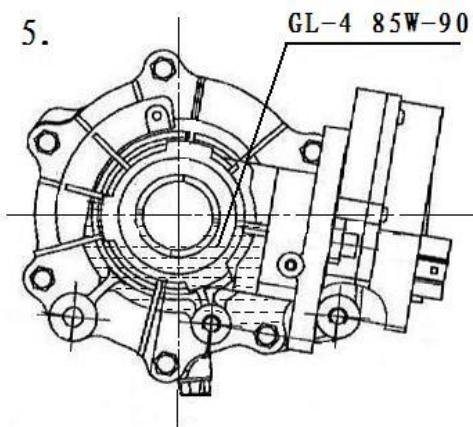

### Lubrication Recommendations

	Item	Lube Rec	Method	Frequency
●	6. Front/Rear A-arm pivot Shaft	Grease	Locate fitting on pivot shaft and grease with grease gun	Every 3 months or 50 hours

## 16. MAINTENANCE

●	7. Steering Post Bushings	Grease	Locate fitting on pivot shaft and grease with grease gun	300km and every 1000km
●	8. Front/Rear Wheel bearings	Grease	Inspect and replace bearings if necessary	300km and every 1000km
	9. Tie rods	Grease	Locate fittings and Grease	300km and every 1000km
	10. Front/Rear Prop Shaft & Shaft Yoke	Grease	Locate fittings and Grease	300km and every 1000km
●	11. Ball joints	Inspect	Inspect and replace it if necessary	300km and every 1000km
●	12. Prop Shaft & Shaft Yoke	Grease	Locate fitting and Grease	300km and every 1000km
●	13. Throttle Cable	Grease M	Grease, inspect and replace it if necessary	300km and every 1000km
●	14. Rear Axle Bearing (on swing arm model)	Grease	Locate fittings and grease	300km and every 1000km
●	15. Swing Arm Bearing (on swing arm model)	Grease	Locate fittings and grease	300km and every 1000km



## 16. MAINTENANCE

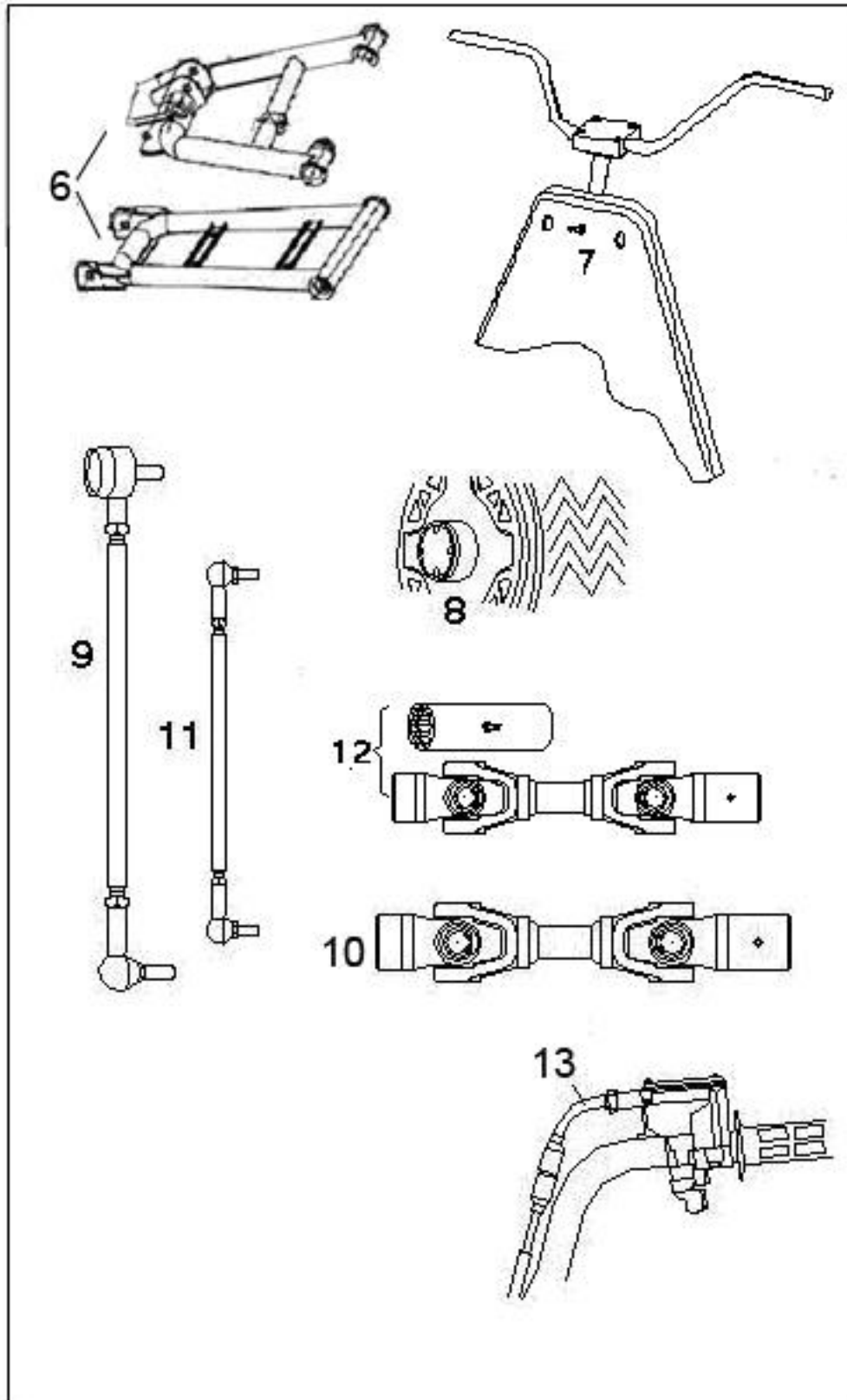

## 16. MAINTENANCE

---

**NOTE:**

1. More often under severe use, such as wet or dusty conditions .
2. Grease: Light weight lithium-soap grease.
3. Grease M: molybdenum disulfide(MoS<sub>2</sub>) grease(water resistant).
4. \*When suspension action becomes stiff or after washing.
5. Hours are based on 10 mph(16Km/h) average.

**Periodic Maintenance Record**

Use the following chart to record periodic maintenance work:

Maintenance Interval Performed	Servicing Date	Servicing Dealer or Person	Remarks
First 5 Hrs			
10 Hrs			
15 Hrs			
20 Hrs			
25 Hrs			
50 Hrs			
75 Hrs			
100 Hrs			

## 16. MAINTENANCE



### WARNING

Improper adjustment of the handlebars or incorrect torque of the adjuster block tightening bolts can cause limited steering or loosening of the handlebars, resulting in loss of control and possible serious personal injury or death.

#### Handlebar Adjustment

Your ATV has handlebars which can be adjusted for your personal fit.

1. Remove the handlebar cover.
2. Loosen the four bolts.
3. Adjust handlebar to desired height. Be sure handlebars do not hit gas tank or any other part of machine when turned fully to left or right.
4. Torque handlebar adjuster block to 10-12 ft.lbs(14-16Nm).

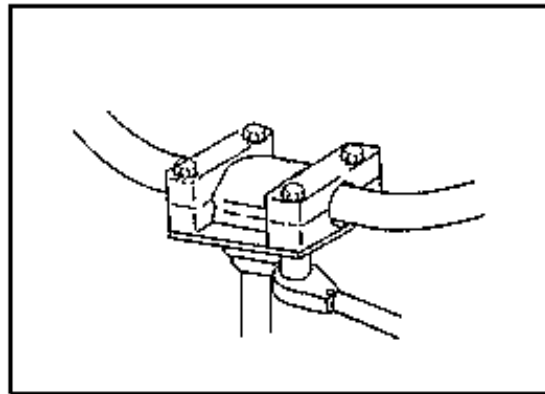

**NOTE:** Tighten bolts so there is an equal gap at the front and rear of the handlebar block. Improper gap will result in improper fit of upper pod.

The following items should be checked occasionally for tightness; or if they have been loosened for maintenance service.

#### Wheel Nut Torque Specifications ( On Independent Suspension model )

Bolt Size	Specification	
Front (ALUMINIUM WHEEL) M12X1.25	69Ft.Lbs	95N.m
Rear (ALUMINIUM WHEEL) M12X1.25	69Ft.Lbs	95N.m

**NOTE:** All nuts that have a cotter pin installed must be serviced by an authorized Dealer.

## 16. MAINTENANCE

---

### Front Wheel Hub Tightening

Front wheel bearing tightness and spindle nut retention are critical component operations. Service work must be performed by an authorized dealer.

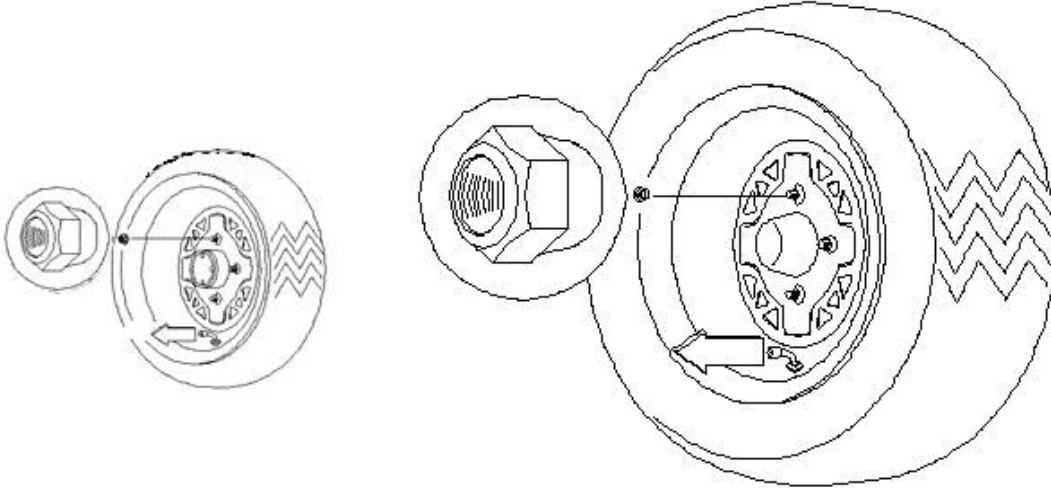

**Tapered nuts: install with tapered side against wheel.**

### Air Filter Service

1. Remove seat.
2. Release clips and remove cover.
3. Loosen clamp and remove Filter.
4. Reinstall filter. Replace filter as required.
5. Reinstall filter into air box and tighten clamp. Do not over tighten clamp or filter damage may occur.

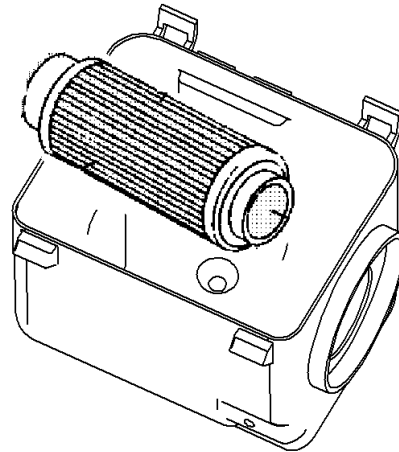

### Steering Inspection

The steering assembly of the machine should be checked periodically for loose nuts and bolts. If loose nuts and bolts are found, have your dealer tighten them before riding your vehicle.

### Camber and Caster

## 16. MAINTENANCE

---

The camber and caster are non-adjustable.



### WARNING

Do not attempt to adjust the tie rod for toe alignment. Severe injury or death can result from improper adjustment.

Contact your dealer. He/she has the training and tools to

Make these adjustment.

---

### Toe Alignment Check

The recommended toe alignment is 1/8" to 1/4" (3 to 6mm) toe out.

1. Set the handlebars in a Straight ahead position and Hold them in this position.
2. Measure A and B, A minus B should be 1/16" to 1/8" (1.5 to 3mm).
3. If this measurement needs to be adjusted, contact your dealer for service.

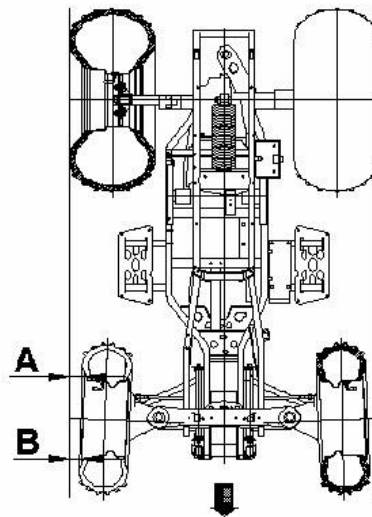

### Front Brake

## 16. MAINTENANCE

---



### WARNING

Once a bottle of brake fluid is opened, use what is necessary and discard the rest. Do not store or use a partial bottle of brake fluid. Brake fluid is hygroscopic, meaning it rapidly absorbs moisture from the air. This causes the boiling temperature of the brake fluid to drop, which can lead to early brake fade and the possibility of serious injury.

---

The front brake is hydraulic disc brakes which is depressing the foot pedal on the side of the right floorboard. These brakes are self-adjusting and require no adjustment.

The following checks are recommended to keep the brake system in good operating condition. How often they need checking depends upon the type of driving that has been done.

- Keep fluid level in the master cylinder reservoirs as described see “7.Control and part functions”. Normal functioning of the diaphragm is to extend into the reservoir as fluid level drops. If the fluid level is low and the diaphragm is not extended, a leak is indicated and the diaphragm should be replaced. Always fill the reservoir as indicated whenever the cover is loosened or removed to insure proper diaphragm operation. Use DOT 3 brake fluid.
- Check brake system for fluid leaks.
- Check brake for excessive travel  
Or spongy feel.
- Check friction pads for wear,  
damage and loosened.
- Check security and surface  
condition of the disc.
- Pads should be changed when friction material is worn to 3/64”(1mm).(A)

## Rear and Auxiliary Brake

### Rear Brake

The rear brake is a hydraulic disc type brake which is activated by the same pedal which activates the front brake system is self adjusting and requires no maintenance other than periodic checks of the pads for wear

- Pads should be changed when the friction material is worn to 3/64”(1mm).
- Inspect the brake disc spline and pad wear surface for excessive wear.

### Auxiliary Brake Systems

## 16. MAINTENANCE

---

Your ATV's auxiliary brake system is intended to be used as a backup for the main brake system. Should the main system fail, the rear brake can be activated by the brake lever being moving toward the handlebar. The hydraulic brake system will not require adjustment.

NOTE: Since this is a rear brake only, it will not be as effective as the all wheel system

### Checking

Although the parking brake has been adjusted at the factory, the brake should be checked for proper operation. The mechanical brake must be maintained to be fully functional.

1. With the engine off, apply the parking brake lever and attempt to move the ATV.
2. If the rear wheels are locked, it is adjusted properly.
3. If the wheels are not locked, it must be adjusted.

### Adjusting

**To adjust (set up) the mechanical parking brake, use the following procedure**

**Note:** The adjusting on the caliper is for the wear out of the pads.

1. With the engine off, loosen the adjuster on the lever.
2. Loosen the jam nut of the adjuster on the caliper.
3. Turn the adjuster (bolt) CW (clockwise) by hand till the pad touch the brake disc, turn the adjuster bolt CCW (counterclockwise) by 1/4 to one turn for 10 to 20mm free play at the end of the parking lever.
4. Tighten the jam nuts securely against the adjusters.
5. Make sure the rear wheels turns freely without dragging.
6. Turn the adjuster (the one on the lever) and apply the lever. While adjusting, it is important you apply the lever back and forth for operation, free play and the locking of the parking position.
7. Make sure the rear wheels turns freely without dragging and parking brake works properly.

**CAUTION** Don't over tighten the adjuster. Free play of the lever: 20mm.

8. Field test for parking. It must be capable of holding the laden ATV stationary on an 18% up and down gradient.

The temporary adjusting can be done to the brake cable on the parking lever side by turn the adjuster (nut) directly.

But the adjust range is limited. Always do the **procedure 1 to 8** when necessary.

## 16. MAINTENANCE

---

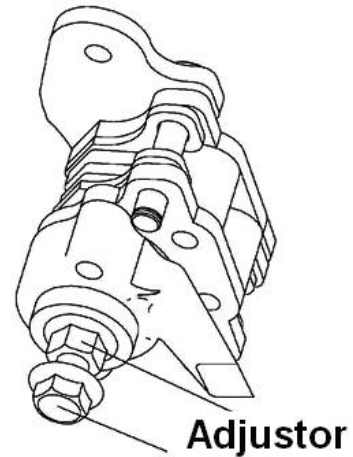
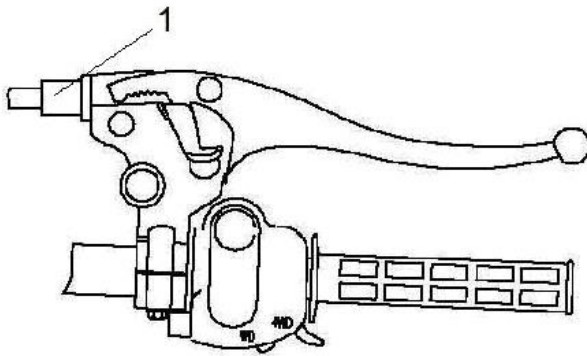

### Throttle Cable Free Play Adjustment

Throttle cable free play is adjusted at the handlebar.

1. Side the bolts off inline cable adjuster, Loosen adjuster locknut.
2. Turn adjuster until 1/16" to 1/8" (2 to 3mm) freeplay is achieved at thumb lever. **NOTE:** While adjusting freeplay, it is important you flip the throttle lever back and forth.
3. Tighten locknut and slide boots over cable adjuster.

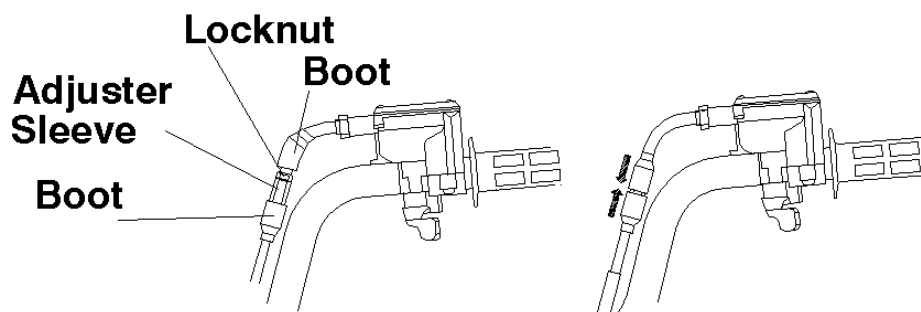



## 16. MAINTENANCE

---

### Spark Plugs

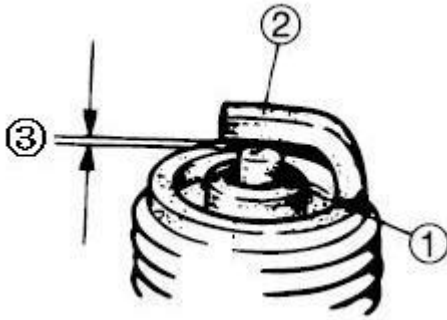

Standard spark plug

DPR8EA-9(NGK)

③ Gap: 0.8-0.9mm

Inspect:

- Insulator ①  
Abnormal color: Replace.  
Normal color is a medium-To-light tan color.
- Electrode ②  
Wear/damage: Replace. Clean:
- Spark plug  
(with spark plug cleaner or wire brush)

Measure:

- Spark plug gap ③  
Out of specification: Adjust gap.

### Spark Plug Removal and Replacement



#### WARNING

Never attempt to remove a spark plug while the engine is warm. The exhaust system or engine could burn you causing severe injury.

---

Remove the spark plug by rotating counterclockwise.

Reverse the procedure for spark plug installation. Torque to 17ft.lbs (23N.m).

### Oil and Filter Change

## 16. MAINTENANCE

---

The recommended oil change interval is 30 hours, or every 3 months, whichever comes first. Suggested break in oil change is at 20 hours, or one month, whichever comes first. Severe use operation requires more frequent service. Severe use includes continuous duty in dusty or wet conditions, and cold weather riding.

**NOTE:** Severe use cold weather riding is all riding below 10°F(-12°C), and riding between 10°F (-12°C) and 30°F (0°C) when most trips are slow speed and less than 5 mph (8km/h). Be sure to change the oil filter whenever changing oil



### CAUTION

Oil may be hot. Do not allow hot oil to come into contact with skin as severe burns may result

---

1. Place vehicle on a level surface;
2. Run engine two or three minutes until warm, Stop engine;
3. Clean area around drain plug;
4. Place a drain pan beneath engine crankcase and remove drain plug;
5. Allow oil to drain completely;
6. Reinstall drain plug and torque to 18ft.lbs (25N.m)

### Rear Gear-case Lubrication

## 16. MAINTENANCE



### CAUTION

Be sure no foreign material enters the gear case.

With the ATV on a level surface, remove fill plug and visually inspect the lubricant level through the fill hole. Lubricant should be kept even with the center of the drill point approximately below the top of the fill hole.

NOTE: Do not add lubricant to the bottom of the fill plug threads. The correct gearcase lubricant to use is SAE GL-4 85W/90 Weight Gear Lube.

### Oil Changing Procedure

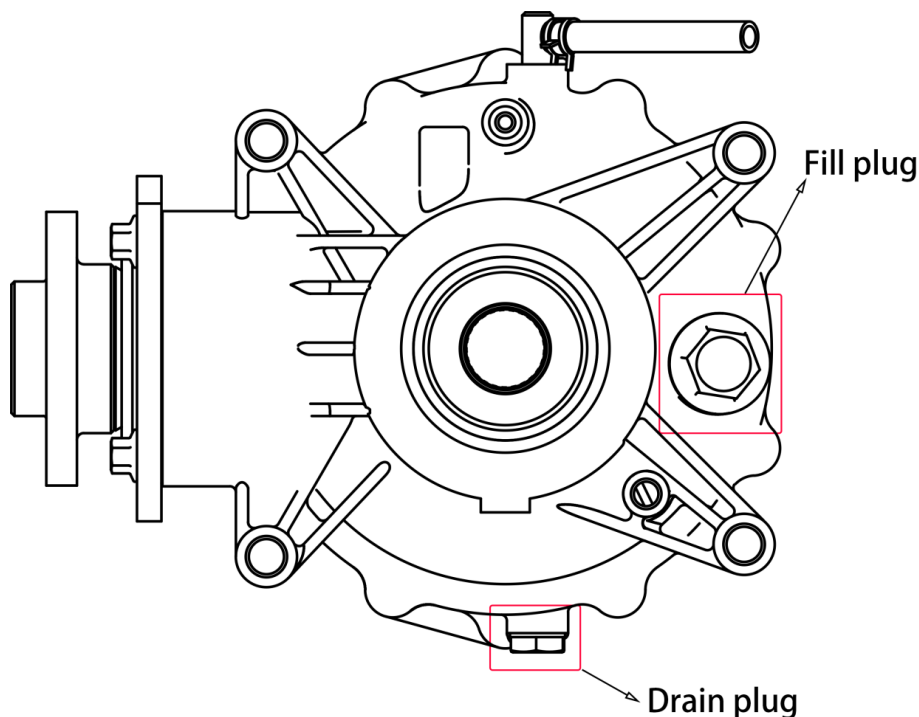

1. Remove the drain plug . Catch and discard used oil properly.
2. Clean and reinstall the drain plug with a new sealing washer and tighten securely (14 ft. lbs/20N.m).
3. Remove the fill plug and add 10 ounces (250ml) of SAE GL-4 85W/90 Weight Gear Lubricant and inspect oil level. Oil level should be kept even with the center of the drill point (approximately below the top of the fill hole).
4. Reinstall the fill plug. Tight securely (24.5 ft. lbs/35N.m).
5. Check for leaks.

### Diff Rear Gearcase Lubrication

## 16. MAINTENANCE



### CAUTION

Be sure no foreign material enters the gear case.

With the ATV on a level surface, remove fill plug and visually inspect the lubricant level through the fill hole. Lubricant should be kept even with the center of the drill point approximately below the top of the fill hole.

NOTE: Do not add lubricant to the bottom of the fill plug threads. The correct gearcase lubricant to use is SAE GL-4 85W/90 Weight Gear Lube.

### Oil Changing Procedure

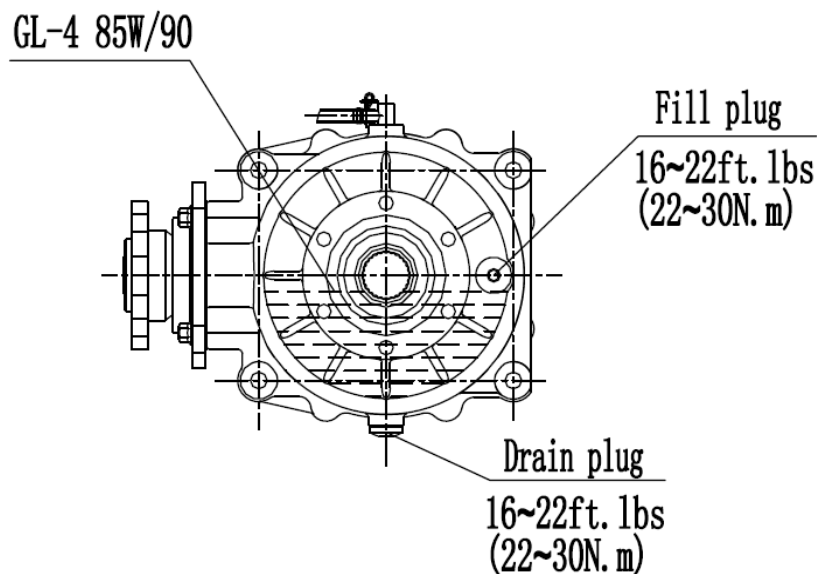

1. Remove the drain plug. Catch and discard used oil properly.
2. Clean and reinstall the drain plug with a new sealing washer and tighten securely (16~22ft. lbs/22~30N.m).
3. Remove the fill plug and add 10 ounces (300ml) of SAE GL-4 85W/90 Weight Gear Lubricant and inspect oil level. Oil level should be kept even with the center of the drill point (approximately below the top of the fill hole).
4. Reinstall the fill plug. Tight securely (16~22 ft. lbs/22~30N.m).
5. Check for leaks.

### Front Gearcase Lubrication

## 16. MAINTENANCE

---



### CAUTION

Be sure no foreign material enters the gear case.

With the ATV on a level surface, remove fill plug and visually inspect the lubricant level through the fill hole. Lubricant should be kept even with the center of the drill point approximately below the top of the fill hole.

NOTE: Do not add lubricant to the bottom of the fill plug threads. The correct gearcase lubricant to use is SAE GL-4 85W/90 Weight Gear Lube.

### Oil Changing Procedure

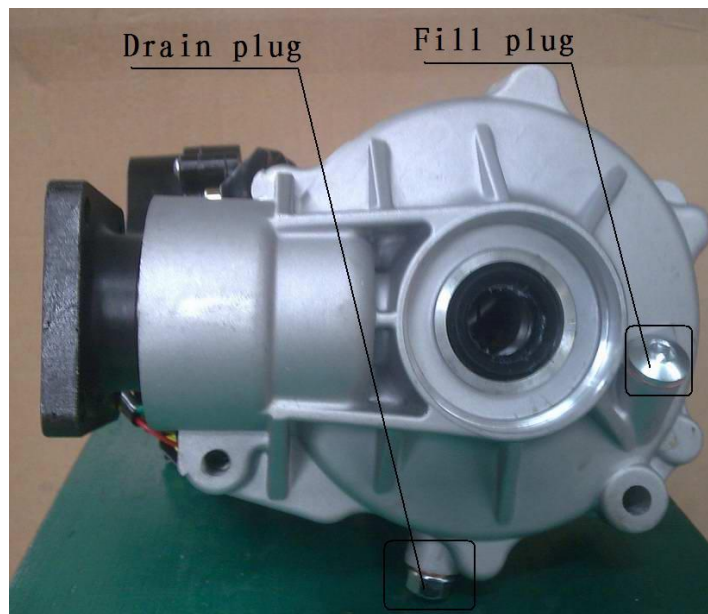

1. Remove the drain plug. Catch and discard used oil properly.
2. Clean and reinstall the drain plug with a new sealing washer and tighten securely (14 ft. lbs/20N.m).
3. Remove the fill plug and add 11 ounces (330ml) of SAE GL-4 85W/90 Weight Gear Lubricant and inspect oil level. Oil level should be kept even with the center of the drill point (approximately below the top of the fill hole).
4. Reinstall the fill plug. Tight securely (24.5 ft. lbs/35N.m).
5. Check for leaks.



### WARNING

## 16. MAINTENANCE

Operating your ATV with worn tires, improperly inflated tires, non-standard tires or improperly installed tire will affect vehicle handling which could cause an accident resulting in serious injury or death.

Follow the safeguards listed below to prevent this type of situation.

### Important Safeguards

Maintain proper tire pressure according to charts below. Improper tire inflation may affect ATV maneuverability.

Do not use improper tires. The use of non-standard size or type tires may affect ATV handling.

Make certain the wheels are installed properly. If wheels are improperly installed it could affect vehicle handling and tire wear.

### Wheel Removal Procedure

1. Stop the engine, place the transmission in gear and lock the parking brake.
2. Loosen the wheel nuts slightly.
3. Elevate the side of the vehicle by placing a suitable stand under the footrest frame.
4. Remove the wheel nuts and remove the wheel.

Tire Pressure		
	front	rear
EURO4, 5	35kPa/5PSI	35kPa/5PSI
T3 EFI	48kPa/7PSI	48kPa/7PSI

### Wheel Installation

1. With the transmission in gear and the parking brake locked, place the wheel in the correct position on the wheel hub. Be sure the valve stem is toward the outside and rotation arrows on the tire point toward forward rotation.
2. Attach the wheel nuts and finger tighten them.
3. Lower the vehicle to the ground.
4. Securely tighten the wheel nuts according to the chart found in

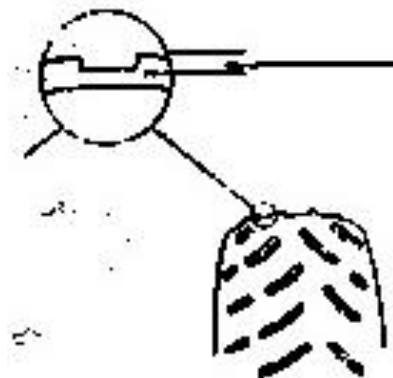

“16.MAINTENANCE/Wheel Nut Torque”.

## 16. MAINTENANCE

---

### Tire Inspection

When replacing a tire always use original equipment size and type.

### Tire Tread Depth

Always replace tires when tread depth is worn to 1/8" (3mm) (1) or less. Please refer to your Owner's Manual for tire specifications.

### Headlight Lamp Replacement



#### **WARNING**

Keep your headlights and taillights clean. Poor light while riding can result in an accident causing severe injury or death.

---



#### **CAUTION**

Do not service while headlight is hot. Serious burns may result.

Do not touch a halogen lamp with bare fingers. Oil from your skin leaves a residue, causing a hot spot which will shorten the life of the lamp.

---

### Lamp Replacement

**The Headlight/position light(LED) Replacement.**

## 16. MAINTENANCE

---

1. If the headlight/position light does not work, it may need to be replaced
2. Remove mounting screw.
3. Unplug light from harness.
4. Test the light to see.
5. Install new light and reassemble

### Taillight /Brake light Lamp Replacement

If the taillight / brake light does not work the lamp may need to be replaced.

6. Remove the lens.
7. Remove lamp and replace it with recommended lamp.
8. Test the taillight/ brake light to see that it's working .
9. Reinstall the lens.

### Indicator Lamp Replacement

1. Remove mounting panel.
2. Unplug light from harness, depress locking tabs (A) and remove from pod.
3. Install new light and reassemble panel.

### High beam Headlight Adjustment

The High beam headlight can be adjusted up and down.

1. Place the vehicle on a level surface with the headlight approximately 10”(3m) from a wall.
2. Measure the distance from the floor to the center of the headlight and make a mark on the wall at the same height.
3. Start the engine and turn the headlight switch to high beam.
4. Observe headlight aim. The most intense part of the headlight beam should be aimed 2.8” (71mm) below the mark placed on the wall in step 2. **NOTE** : Riding weight must be included on the seat.
5. To turn the two adjusting bolt ① clockwise is to heighten the beam area and to turn the two adjusting bolt ① counterclockwise is to lower the beam area.

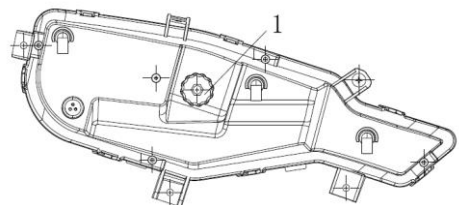

**The dipper headlight adjustment is the same to the High beam Headlight.**

### Cleaning Your ATV

Keeping your ATV clean will extend the life of various components.



## 16. MAINTENANCE

---

### Washing

Never use a high pressure type car wash system, it can damage to the wheel bearings, transmission seals, body panels, brakes and warning labels, and water might enter the engine or exhaust system.

The best and safest way to clean your ATV is with a garden hose and a pail of mild soap and water. Use a professional type washing mitten, cleaning the upper body first and lower parts last. Rinse with water frequently and dry with a chamois to prevent water spots. **NOTE:** If warning labels are damaged, contact your dealer for replacement.

### Warning

Your ATV can be waxed with any non-abrasive automotive paste wax. Avoid the use of harsh cleaners since they can scratch the body finish.



### CAUTION

Certain products, including insect repellants and chemicals, will damage plastic surfaces. Care must be taken when using these products plastic surfaces.

---

### Storage Tips



### CAUTION

Do not start the engine during the storage period. This will disturb the protective film created by fogging.

---

**Cleaning**—Clean the ATV thoroughly.

**Fuel**—Turn the fuel valve to “OFF”.

**Oil Add and Filter Change**—Warm the engine and change oil and filter.

**Air Filter/Air Box**—Inspect and clean or replace the pre-cleaner and air

## 16. MAINTENANCE

---

filter. Clean the air box and drain the sediment tube.

**Inspect All Fluid Levels**—Inspect the following fluid levels and change if necessary: transmission; brake fluid (change every two years or as required if fluid looks dark or contaminated).

**Fog the Engine**—Spray a light oil into the cylinder through the spark plug hole.

**Check and Lubricate Cables/Grease**—Inspect all cables and lubricate.

**Battery Maintenance**—Remove the battery and add distilled water as required to the proper level. Do not use tap water which may contain minerals that reduce battery life. Apply Dielectric Grease to the terminal bolts and terminals. Charge the battery.

**Storage Area/Covers**—Set tire pressure and safely support the ATV with the tires 1-2”(25-50mm) off the ground. Be sure the storage area is well ventilated. Cover the machine with a ATV cover.

**NOTE:** Do not use plastic or coated materials. They do not allow enough ventilation to prevent condensation, and may promote corrosion and oxidation.

### Transporting

Whenever the ATV is to be transported the following measures should be taken.

1. Turn off the engine and remove the key.
2. Turn the fuel valve to off.
3. Be certain the fuel cap, oil cap, and seat are installed correctly.
4. Always tie the frame of the ATV to the transporting until securely using suitable straps or rope.
5. Always place the transmission in gear and lock the parking brake.

# 17. TROUBLESHOOTING

---

## Issues of Improper Operation Driven Clutch (CVT) Burning

Possible Causes	Solutions
Loading the ATV into a pickup or tall trailer when in high range.	Shift transmission to Low Range during loading of the ATV to prevent belt burning
Starting out going up a steep incline	When starting out on an incline, use low range, or dismount the ATV after first applying the park brake and perform the "K" turn as described in this manual.
Driving at low RPM or low ground speed (at approximately 3-7MPH/ 5-12km/h)	Drive at higher speed or use low range. The use of low range is highly recommended for cooler CVT operating temperatures and longer component life.
Insufficient warm-up of ATV's exposed to low ambient temperatures.	Warm engine at least 5 min., then with transmission in neutral, advance throttle to approx. 1/8throttle in short bursts, 5 to 7 times. The belt will become more flexible and prevent belt burning.
Slow and easy clutch engagement.	Fast, effective use of the throttle for efficient engagement.
Towing /Pushing at low RPM/low ground speed.	Use Low Range only.
Stuck in mud or snow.	Shift the transmission to Low Range carefully use fast, aggressive throttle application to engage clutch. <b>WARNING:</b> Excessive throttle may cause loss of control and vehicle overturn.
Climbing over large objects from a stopped position.	Shift the transmission to Low Range carefully use fast, brief, aggressive throttle application to engage clutch. <b>WARNING:</b> Excessive throttle may cause loss of control and vehicle overturn.

## 17. TROUBLESHOOTING

---

### Battery Wane

Possible Cause	Solutions
Starting a faulty engine for long time	See "8.STARTING THE ENGINE" And check the fuel/ air/ ignition/ compression system
Let the main switch (key) on while parking the ATV	When stopping the engine, turn off the main switch (key) off at once

### For LH500ATV-D (EFI Model)



### WARNING

This ATV is equipped with EFI system ,If the battery is under 12 Volt, the engine will not start.

---

**NOTE:**

# 17. TROUBLESHOOTING

---

The following troubleshooting does not cover all the possible causes of trouble. It should be helpful, however, as a guide to troubleshooting. Refer to the relative procedure in this manual for inspection, adjustment and replacement of parts. Adjustment and replacement must be done by your dealer.

---

## STARTING FAILURE/ HARD ATARTING FUEL SYSTEM

### EFI

#### Fuel tank

- Empty
- Clogged fuel tank breather pipe
- Deteriorated fuel or fuel containing water or foreign material
- fuel filter clogging
- the fuel pressure not correct

#### Throttle body

- The connect not good

#### Air cleaner

- Clogged air cleaner element
- Improper air cleaner setting

## COMPRESSION SYSTEM

### Cylinder and cylinder head

- Loose spark plug
- Loose cylinder head
- Broken cylinder head gasket
- Broken cylinder gasket
- Worn, damaged or seized cylinder

### Piston and Piston ring

- Worn piston
- Worn fatigued or broken piston ring
- Seized piston ring
- Seized or damaged piston

### Valve system

- Improperly adjusted valve clearance
- Improperly sealed valve
- Improperly contacted valve and vale seat
- Improper valve timing
- Broken valve spring
- Seized valve

## IGNITION SYSTEM

### Battery

- Improperly charged battery
- Faulty battery

### Fuse

- Burnt out, improper connection

### Spark plug

- Improper plug gap
- Worn electrodes

### Ignition system

- Faulty ignitor unit
- Faulty pick up coil
- Broken magneto woodruff key

### Switch

- Faulty main switch
- Faulty "ENGINE STOP"

# 17. TROUBLESHOOTING

---

- Wire between terminals broken
- Improper heat range
- Faulty spark plug cap

## Ignition coil

- Broken or shorted primary/  
secondary coil
- Faulty high tension cord
- Broken ignition coil body

- switch
- Faulty brake switch

## Wiring

- Loose battery terminal
  - Loose coupler connection
  - Improperly grounded
  - Broken wireharness
- 

## POOR IDLE SPEED PERFORMANCE

### Air cleaner

- Clogged air cleaner element

### Ignition system

- Faulty spark plug
- Faulty high tension cord
- Faulty ignitor unit
- Faulty pick up coil
- Faulty ignition coil

### Valve system

- Improperly adjusted
- valve clearance

## EFI

- the fuel pressure not correct
- fuel injector clogging
- fuel filter clogging

## POOR MEDIUM AND HIGH SPEED PERFORMANCE

### Air cleaner

- Clogged air cleaner element

## EFI

- the fuel pressure not correct
  - fuel filter clogging
  - fuel injector clogging
-

# 17. TROUBLESHOOTING

---

## POOR SPEED PERFORMANCE

### Ignition system

- Dirty spark plug
- Improper heat range
- Faulty igniter unit
- Faulty pick up coil

### Fuel system

- Clogged fuel tank breather hole
- Clogged air cleaner element
- Clogged jet
- Improperly adjusted fuel level

### Compression system

- Worn cylinder
- Worn or seized piston ring
- Cylinder head gasket broken
- Cylinder gasket broken
- Carbon deposit buildup
- Improper adjusted valve clearance
- Improper contacted valve and valve seat
- Faulty valve timing

- the fuel pressure not correct
- fuel filter clogging

### Clutch

- Refer to “CLUTCH SLIPPING /DRAGGING” section

### Engine oil

- Improper oil level (low or over Oil level)

### Ignition system

- Faulty spark plug
- Faulty high tension cord
- Faulty ignitor unit
- Faulty pick up coil
- Faulty ignition coil

### Valve system

- Improperly adjusted valve clearance

## OVER HEATING OR OVER-COOLING

### OVER HEATING

#### Ignition system

- Improperly spark plug gap
- Improper spark plug heat range
- Faulty igniter unit

#### Fuel system

- Improper fuel level adjustment
- Clogged air cleaner element

#### Compression system

### OVER-COOLING

#### Cooling system

- Faulty thermostat
- Faulty thermo switch

# 17. TROUBLESHOOTING

---

- Heavy carbon deposit build-up
- Improperly adjusted valve timing
- Improperly adjusted valve clearance

## Engine oil

- Incorrect engine oil level
- Improper engine oil quality (High viscosity)
- Low engine oil quality

## Brakes

- Dragging brake

## Cooling system

- Inoperative fan motor
- Faulty thermostat
- Faulty thermo switch
- Incorrect coolant level (low coolant level)
- Faulty radiator (Clogged, damage)
- Faulty radiator cap
- Impeller shaft gear malfunction (bent dowel pin, gear)
- Damaged impeller shaft
- Disconnected fan motor connector

## FAULTY CLUTCH

### WHEN ENGINE RUN, ATV DOES NOT RUN

#### V belt

- Worn/bent/slipping

#### Cam, slider

- Worm/damaged

#### Compression spring

- Damage

#### Gears

- Damage

### CLUTCH SLIPPING

#### Clutch weight spring

- Worn/loose

#### Clutch shoe

- Worn/ damaged

#### Primary sliding sheave

### POOR SPEED PERFORMANCE

#### V-belt

- Worn
- Oil V belt

#### Roller weight

- Worn/improper operation  
primary/secondary/sheave

- Worm

### CVT SYSTEM

#### Uncorrect Primaty Clutch Position

- Uncorrect engine mount  
(see 13. CVT system)



## 17. TROUBLESHOOTING

---

- Seized

### **POOR STARTING PERFORMANCE**

#### **V-belt**

- Slipping/oily V-belt

#### **Primary sliding sheave**

- Improper operation
- Damage

#### **compressing spring**

- Worn/loose

#### **Secondary sliding sheave**

- Improper operation
- Worn guide pin groove
- Worn guide pin

#### **Clutch shoe**

- Worn/ bent

### **FAULTY BRAKE**

#### **POOR BRAKING**

#### **EFFECT**

- Worn front hub bearing
- Worn brake pad
- Worn brake disc
- Air in brake fluid
- Leaking brake fluid
  
- Faulty master cylinder kit
- Faulty caliper seal kit
- Loose union bolt
- Broken brake hose
- Oily or greasy brake pad
- Oily or greasy brake disc

## 18. TOOL

---



**Spark Plug Wrench**



**Wrench (8, 10mm)**

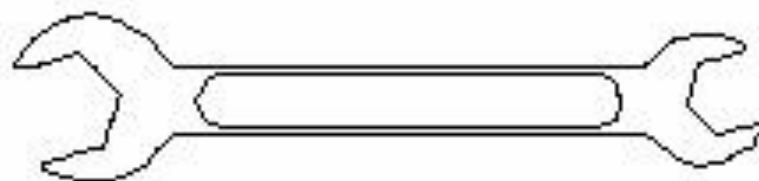

**Wrench  
(12, 14mm)**

## 19. SPECIFICATION

### LH570ATV Euro 4, 5

Model	LH570ATV-ProMax (Euro 4, 5)	
Fuel capacity	12.5L	3.3U.S.Gal
Engine Oil Capacity	2.2L	0.58 U.S.Gal
Ground Clearance	280mm	11 inch
Height	1270mm	50 inch
Length	2155mm	84.8inch
Width	1180mm	46.5 inch
Seat height	960mm	37.8 inch
Wheel Base	1275mm	50.2 inch
Turn diameters	6500mm	256 inch
Dry Weight	355kg	782.6 lbs
Front Rack	10kg	22 lbs
Rear Rack	20kg	44 lbs
Load Capacity(Combined Rider& Payload)	150kg	350 lbs
Tongue Weight	10kg	22 lbs
Tow Capacity	180kg	396 lbs
<b>Drive System</b>		
Drive System	CVT	
Front Tire	25X8-12	
Rear Tire	25X10-12	
Tire Pressure	front	rear
	35kPa (5PSI)	35kPa (5PSI)
<b>Brake System</b>		
Service Brake	Front Brake	Hydraulic Disc
	Rear Brake	
Parking Brake	All Wheel	Hydraulic Lock
Auxiliary Brake	Rear Brake	Hydraulic Disc

# 19. SPECIFICATION

## LH570ATV ProMax T3 EFI

Capacities				
Model	LH570ATV-ProMax T3 EFI			
Fuel capacity	12.5L	3.3U.S.Gal		
Engine Oil Capacity	2.2L	0.58 U.S.Gal		
Ground Clearance	270mm	10.6 inch		
Height	1480mm	58.3 inch		
Length	2240mm	88.2inch		
Width	1160mm	45.7 inch		
Seat height	900mm	35.4 inch		
Wheel Base	1270mm	50 inch		
Turn diameters	6500mm	256 inch		
Dry Weight	370kg	816 lbs		
Front Rack	10kg	22 lbs		
Rear Rack	20kg	44 lbs		
Load Capacity(Combined Rider& Payload)	175kg	385 lbs		
Tongue Weight	11kg	25 lbs		
Tow Capacity	229kg	504 lbs		
Drive System				
Drive System	CVT			
Front Tire	Load capacity	Technically permissible maximum mass per axle	Maximum permissible vertical load	Tire Pressure
AT25X8.00-12 47F	175kg	350kg	10kg	48kPa(7PSI)
AT25x8.00-12 73F	365kg	730kg	10kg	48kPa(7PSI)
AT25x8.00-12 38N	132kg	264kg	10kg	35kPa(5PSI)
AT25x8.00-12 43F	155kg	310kg	10kg	48kPa(7PSI)
AT25x8.00-12 43J	155kg	310kg	10kg	48kPa(7PSI)
AT25x8.00-12 65J	290kg	580kg	10kg	48kPa(7PSI)
AT25x8.00-12 47F	175kg	350kg	10kg	48kPa(7PSI)
Rear Tire	Load capacity	Technically permissible maximum mass per axle	Maximum permissible vertical load	Tire Pressure

## 19. SPECIFICATION

			load	
AT25X10.00-12 65F	290kg	580kg	10kg	48kPa(7PSI)
AT25x10.00-12 79F	437kg	874kg	10kg	48kPa(7PSI)
AT25x10.00-12 45N	165kg	330kg	10kg	35kPa(5PSI)
AT25x10.00-12 50F	190kg	380kg	10kg	48kPa(7PSI)
AT25x10.00-12 50J	190kg	380kg	10kg	48kPa(7PSI)
AT25x10.00-12 70J	335kg	670kg	10kg	48kPa(7PSI)
AT25x10.00-12 65F	290kg	580kg	10kg	48kPa(7PSI)
Noise	According to directive (EU) 2018/895		Noise of ATV in motion	83 dB(A)
<b>Brake System</b>				
Service Brake	Front Brake	Hydraulic Disc		
	Rear Brake			
Parking Brake	All Wheel	Hydraulic Lock		
Auxiliary Brake	Rear Brake	Hydraulic Disc		

<b>Engine</b>	
Engine Type	LH191MR 4Stroke, Single Cylinder, SOHC
Bore x Stroke	91mmX76.8mm
Displacement	499.5cc
Starter System	Electric Starter
Engine Cooling	Liquid-Cooled
Lubrication System	Wet Sump
Ignitions	ECU
Spark Plug Type	DPR8EA-9 ( NGK )

## 19. SPECIFICATION

---

### LH570ATV-ProMax

Electrical Equipment	
Battery	12V 18AH
Head light	7.8W/7.2W
Brake/ Tail Light	21W/5W
Front Flasher Light	LED
Rear Flasher Light	12V 10WX2
Mark Light	12V 5W

